



PATIO HEATER INSTRUCTION MANUAL

Model # 40001

CITADEL Pyramid Heater

WARNING

FIRE OR EXPLOSION MAY RESULT
IF INSTRUCTIONS ARE IGNORED

It is the consumer's responsibility to see that the patio heater is properly assembled, installed, and taken care of. Failure to follow instructions in this manual could result in bodily injury and/or property damage.

PRECAUTIONS

- Leak test all connections after each tank refill.
- Never check for leaks with a match or open flame.
- Do not store or use gasoline or other flammable substances in the vicinity of this or any other appliance.
- Any LP cylinder not connected for use should not be stored in the vicinity of this or any other appliance.

**** FOR YOUR SAFETY IF YOU SMELL GAS ****

1. Turn off the gas supply at cylinder.
2. Extinguish all flames;
3. Do not operate any electrical appliances.
4. Ventilate the area.
5. Check for leaks as detailed in this manual.
6. If odor persists, contact your dealer or gas supplier immediately.

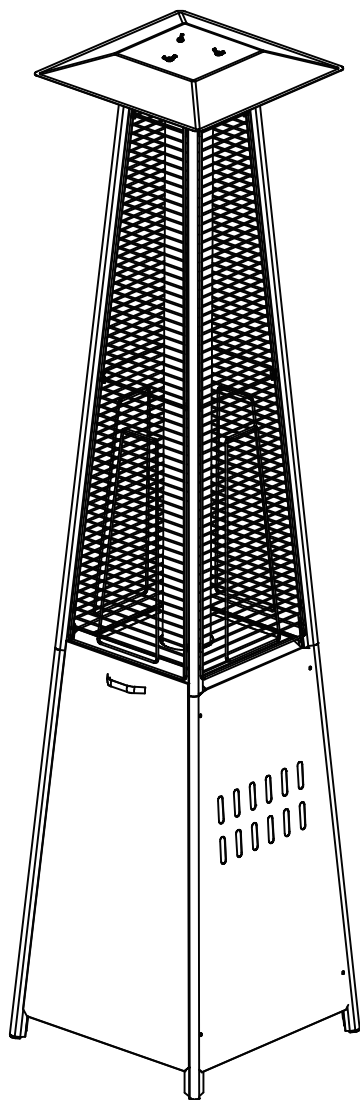

FOR OUTDOOR USE ONLY | USES LPG ONLY
PLEASE READ INSTRUCTIONS CAREFULLY BEFORE ASSEMBLY
RETAIN THIS MANUAL FOR REFERENCE



800.215.1990



sales@thpus.com



touchstonehomeproducts.com

 **DANGER**



CARBON MONOXIDE HAZARD

This appliance can produce carbon monoxide which has no odour.

Using it in an enclosed space can kill you.

Never use this appliance in an enclosed space such as a camper, tent, car or home.

Keep electrical supply cord away from the heated surfaces.

WARNING: Improper installation, adjustment, alteration, service or maintenance can cause injury or property damage. Read the installation, operating and maintenance instructions thoroughly before installing or servicing this equipment.

WARNING :

- For Outdoor Use Only
- LPG Cylinders to be used must be constructed and marked in accordance with US DOT specifications.
- Storage of the heater indoors is permissible only if the gas cylinder is turned off and removed.

NOTE:

- Use only 20lb LP-Gas tank with size of 18.1in / 46cm(Height)*12.5in / 32cm (Width).
- Do not use if the environment temperature is below 40 degrees F / 4.4 degrees C.
- The LP gas cylinder to be used must be provided with a listed overfilling prevention device.
- Do not store a spare LP-gas cylinder under or near this appliance.
- Never fill the cylinder beyond 80 percent full.
- The gas pressure regulator provided with this appliance must be used. This regulator is set for an outlet pressure of 11 inches water column.

Tools needed:

- Open end wrench 10 & 13mm (included)

NOT included:

- Adjustable opening wrench 8" long
- Philips screwdrive rw/ medium blade
- Spray bottle of soapy solution for leak testing
- AA battery (Not included)
- All screws come preinstalled in related parts.

 **WARNING**

This product can expose you to chemicals including carbon monoxide which is known to the State of California to cause birth defects or other reproductive harm. For more information go to www.P65Warnings.ca.gov.

PRECAUTIONS

PLEASE READ THE FOLLOWING SAFETY RULES



WARNING

This heater must only be used outdoors
Using this product in an enclosed area may cause injury, death or property damage.
Read instructions before use.
This heater must be used in accordance with your local area's regulations and bylaws

- Installation and service should be done by a qualified person.
- Do not use the heater in an explosive atmosphere (i.e. areas where gasoline or other flammable liquids or vapors are stored).
- Before use, check the regulator.
- Disconnect LPG cylinder before moving the heater.
- Do not attempt to alter any part of heater.
Example: Using the heater without reflector or protection guard.
- The heater should not be used in basements or below ground level.
- The heater must always be placed on a solid and level surface.
- Never replace or substitute the regulator with a regulator that does not meet the specifications on page 2.
- Do not clean the heater with cleaners that are combustible or corrosive.
- Do not paint any part of the heater.
- The LPG cylinder valve should be turned off and disconnected when the heater is not in use.
- Do not use heater when it is raining, and do not let any liquid splash on the glass tube when the heater is working
- Keep children away from the heater. Always be careful not to knock over the heater, as this could cause breakage of the glass tube and cause injury.
- Do not move the heater when in operation.
- After a long break of operation, the gas parts in the control box of the heater and the hose should be inspected for spiders, spider webs or other insects.
- Check the heater immediately if any of the following exists:
 1. There is smell of gas;
 2. The heater is not burning properly;
 3. The burner makes popping noise during use (a slight popping noise is normal when the burner is extinguished after use).
- If you smell gas, turn off the valve immediately. If smell persists, contact your dealer or gas supplier immediately.
- The hose with regulator assembly should be stored in a safe place to avoid accidental damage.
- Children and adults should be aware of the high surface temperature hazard of the heater, and should keep a safe distance away to avoid clothes burning or igniting.
- Young children should be carefully supervised when they are in the working area of the heater.
- Clothing or other flammable material should not be hung from the heater, or placed on or near the heater.

- Do not obstruct the ventilation holes of the cylinder housing.
- Shut off the valve of gas cylinder or the regulator before moving the appliance.
- The tubing or the flexible hose must be changed within the prescribed intervals.
- Use only the type of gas and the type of cylinder specified by the manufacturer.
- In case of violent wind particular attention must be taken against tilting of the heater.
- Storage of the heater indoors is permitted only if the cylinder is disconnected and removed from the appliance.
- Do not store a spare LPG cylinder under or near this heater.
- Never fill the cylinder beyond 80 percent full.



HEATER PLACEMENT AND LOCATION

- The heater is for outdoor use only.
- Do not use it indoors or in enclosed areas.
- Always ensure that adequate fresh air ventilation is provided
- Always maintain proper clearance from combustible materials (Top: 32 in Side: 26 in)
- Heater must be placed on level firm ground.
- Never operate heater in an explosive atmosphere like in areas where gasoline or other flammable liquids or vapors are stored.

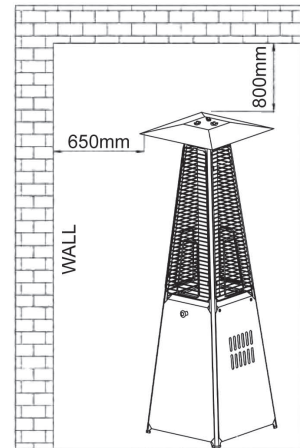

DIAGRAMMATICAL REPRESENTATIONS OF OUTDOOR AREAS

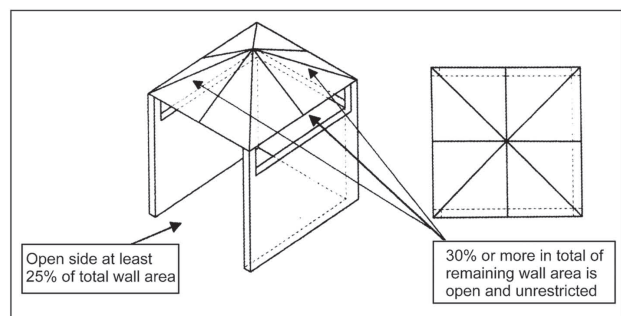
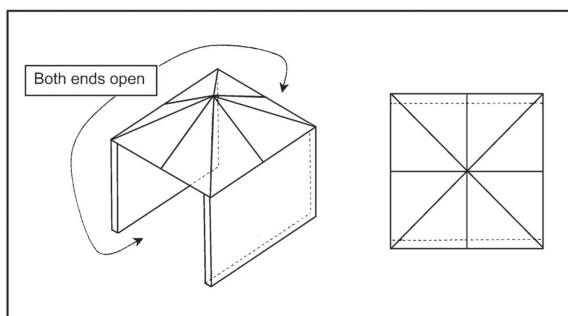
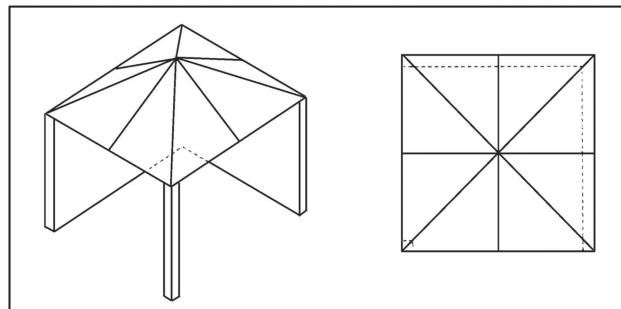
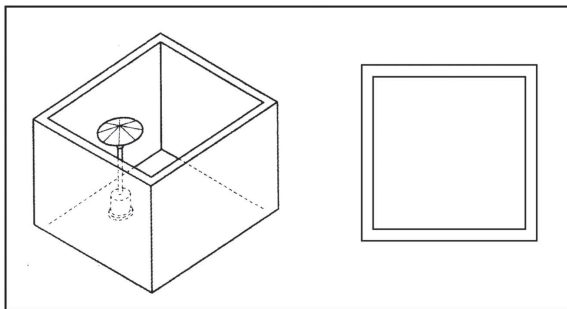

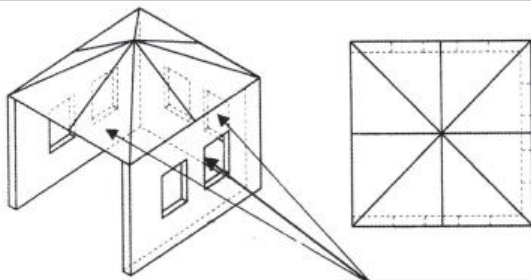

30% or more in total of remaining wall area is open and unrestricted



LEAK TESTING



WARNING
DO NOT SMOKE
WHILE LEAK TESTING

Gas connections on the heater are leak tested at the factory prior to shipment. Possible mishandling of the heater during the shipment might contribute to product integrity as a whole. A complete gas leakage test must be performed again at the installation site.

Please follow the procedure below for leakage test.

1. Make a soapy solution of one part liquid detergent and one part water. The soapy solution can be applied with a spray bottle, brush or rag. Soap bubbles will appear where the leak is present.
2. Make sure the control tap is in the <<OFF>> position (full disk = •) on the control panel.
3. Turn on the gas supply and check for bubbles on the hoses and connections. If the solution starts to bubble that means that a leak is present.
4. If a leak is present, turn OFF the gas supply immediately, tighten any leaking fittings carefully and recheck to see if it still continues to leak.
5. Never leak test while smoking.



















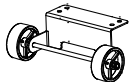

INSTALLATION

Important Safety Rules:

This heater is for OUTDOOR USE ONLY

1. This heater shall not be installed or used indoors, in buildings, garages or any other enclosed area.
2. DO NOT place articles on or against this heater.
3. DO NOT use or store flammable materials near this heater.
4. Children and adults should be aware of the high surface temperature hazard, and should keep a safe distance away to avoid clothes burning or igniting.
5. Children should be carefully supervised when they are in the area of the heater.
6. NEVER hang anything including clothes or other flammable items on the heater.
7. DO NOT operate this heater unless it is fully assembled with the reflector in place.
8. DO NOT SPRAY AEROSOLS IN THE VICINITY OF THIS HEATER WHILE IT IS IN OPERATION.
9. Installation and repair should be done by a qualified person. The heater must be inspected before use and at least annually by a qualified person. More frequent cleaning may be required as necessary. It is imperative that control compartments, burners and circulating air passages of the heater and light be kept clean and free from insect/spider infestation.

PARTS LIST

Part Number	Part Name	Picture	Quantity	Remarks
1	Bottom Plate		1	
2	Control Box		1	
3	Middle Plate		1	Plate Cover is pre-assembled to Middle Plate
4	Damper		1	pre-assembled in the Upper Plate
5	Upper Support		4	
6	Lower Support		4	
7	Glass Tube		1	
8	Reflector		1	
9	Lower Protection Guard		4	
10	Wheels		1	
11	Propane Cylinder Bracket + screws		3	
12	Fixing Bracket		4	
13	Side Panel		3	2 Side panels with vents, 1 Side panel without vents
14	Front Panel		1	
15	Handle		1	
16	Chain×1			
17	AA Battery		1	Not Provided
18	Rubber Ring		1	
19	ScrewM5X8		66	All pre-assembled in relative parts
20	Wing Nut		3	
21	Reflector Studs		3	

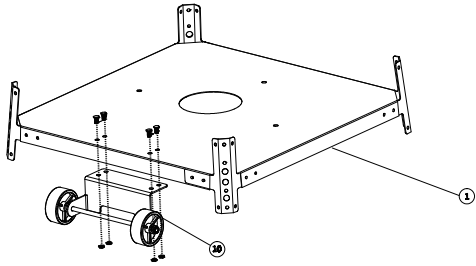

 **Hardware Used:** 4x Bolts and Nuts
(pre-assembled)

1. Attach wheels (10) to bottom plate (1) .

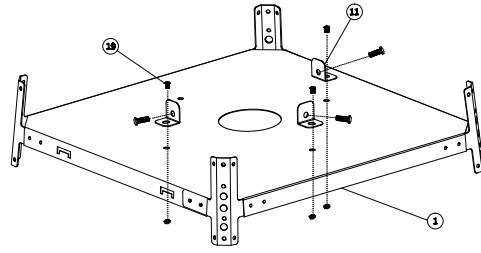

Hardware Used: 3x Bolts and Nuts
(pre-assembled to Brackets)

2. Locate the propane cylinder bracket (11) and attach it on the bottom plate with 3 bolts and nuts provided with the bracket. Use the M8x45 screw to secure the propane cylinder.

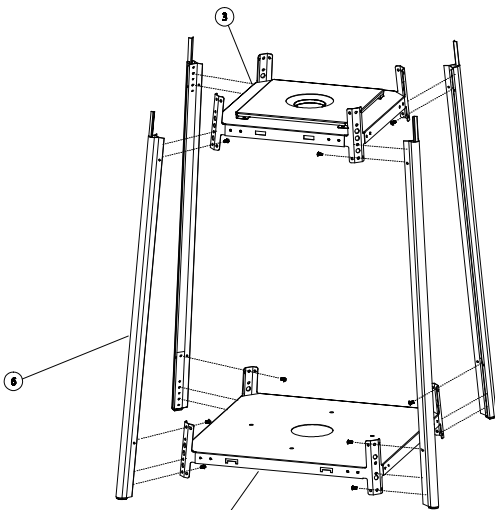

 Opening on Base is opposite side of wheels. Note location of door guides on bases

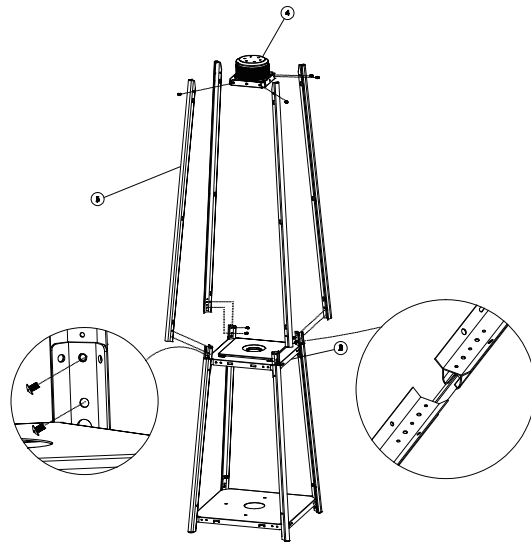

 **Hardware Used:** 20x Screws

3. Connect and fix the 4 lower support (6) to the bottom plate(1) and middle plate (3) with screws (19).

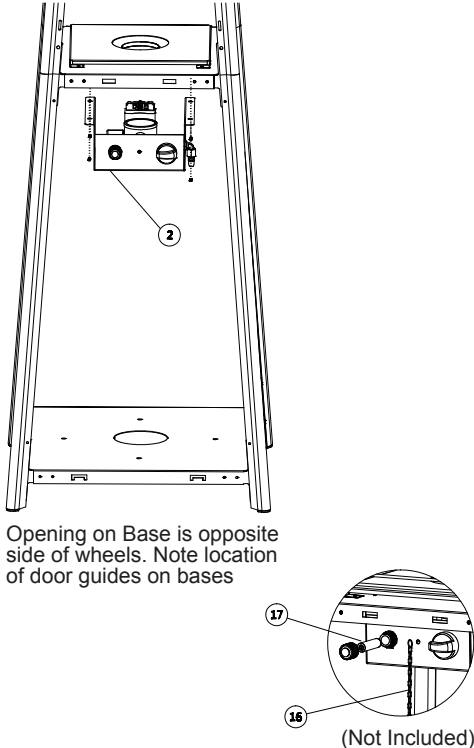

 **Hardware Used:** 12x Screws

4. Connect 4 upper supports (5) to the lower supports (6) with screw (19), then fix the damper with screws (19).

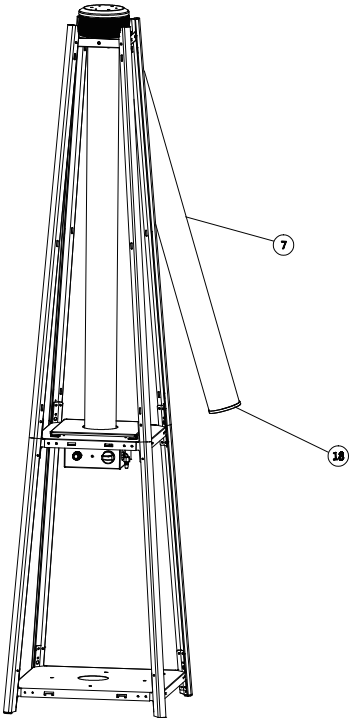
 <p>Opening on Base is opposite side of wheels. Note location of door guides on bases</p> <p>(Not Included)</p> <p> Hardware Used: 1x AA Battery 4x Screws</p>	 <p>Hardware Used: 1x Rubber Ring</p>
<p>5. Unscrew the red igniter button on the control box and insert the AA battery (17) with the POSITIVE end facing upward. Then attach the control box (2) underneath the middle plate (3) with screws (19).</p>	<p>6. Carefully put the glass tube (7) up through the center of the hole in the upper plate (4). Make sure the rubber ring (18) is attached on the lower end of the glass tube. Now place the glass tube through the hole on the middle plate (3). Check to ensure the glass tube covers the center hole of the middle plate.</p>

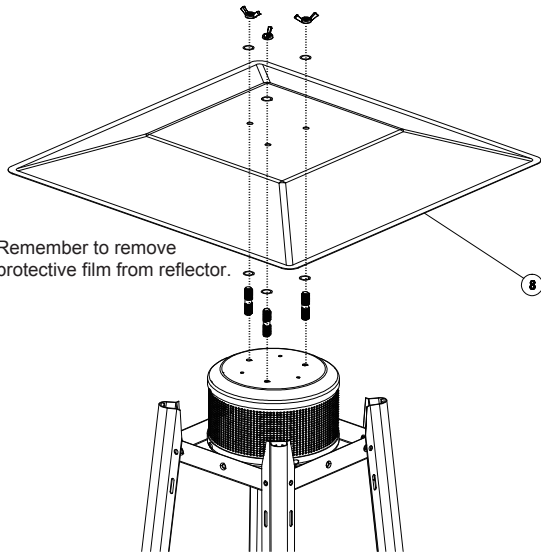

Remember to remove protective film from reflector.



Hardware Used: 3x Studs
3x Wing Nuts

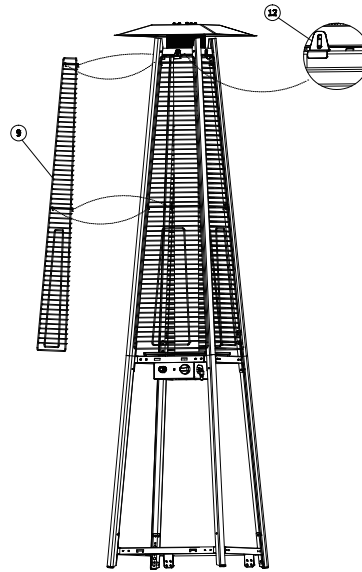

Hardware Used: 4x Screws

7. Attach the bolts onto the damper (4), and put 3pcs washer onto the bolts, then put the reflector (8) onto the bolts, put 3pcs washer through the bolts and fix with screws

8. Attach the protection guards (9) to the upper frame by inserting the hooks at the top of the guards into the holes on the supports. Repeat at the bottom of the supports. Secure the protection guards to the top of the supports with the fixing brackets (12) and screw in place.

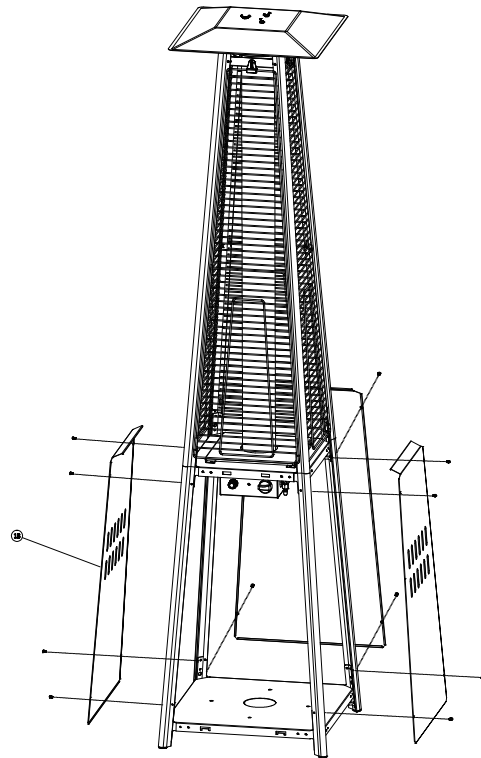

Hardware Used: 12x Screws

9. Fix the sides panels (13) with the screws (19).
Note: Do not cover the side where the control knob is.

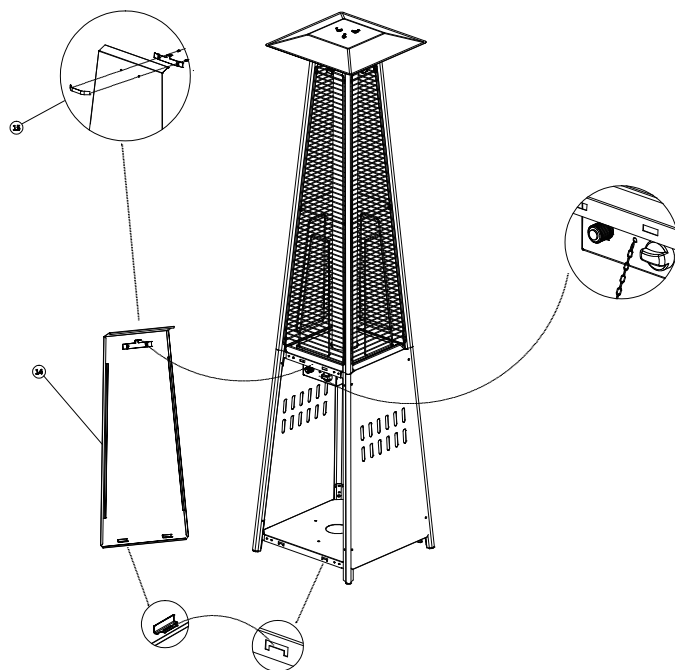

10. Screw the handle (15) on the front panel (14) - attach the panel by inserting its two hooks into the holes on the bottom plate. Hook the chain (16) to the hole in the control box, then close the panel to the middle plate - the panel is attached by the magnets.

Tips: the chain can hole the panel while operating the control.

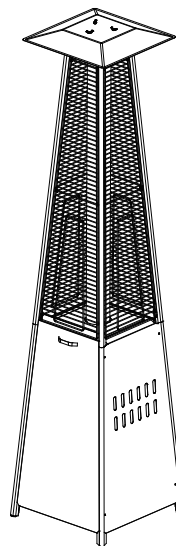

11. Connect gas hose to 20. lb. LPG cylinder (not included). Attach regulator to cylinder. Tighten securely. Move cylinder to the plate of base assembly. Attach the cylinder to the base with 3pcs M8x12 bolts and tighten it in order to prevent the cylinder from moving on the base. Note: The regulator with gas hose is supplied.

Completed



OPERATION

PREPERATION:

You will need to purchase a standard 20 lb. LPG cylinder designed to be used with the regulator purchased or supplied. For correct operation of the gas system follow the instructions supplied with the regulator supplied. Connect the hose to the hose connector in the control box.

Warning: Always test the hose and connections for leaks with soapy water at the end of all connections.

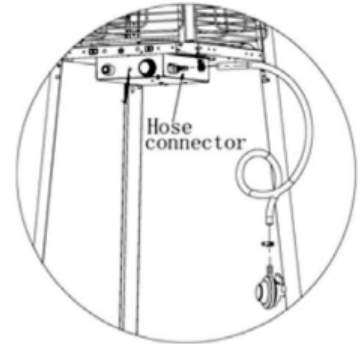

WARNING:

- Never use the heater while it is raining. The glass tube will break when it comes in contact with water.
- Never splash any liquid on the glass tube when the heater is working.
- The glass tube will be extremely hot when it is working. Never try to touch it and do not allow children to try to touch the glass tube.
- Always ensure the heater is on firm, level ground. The glass tube will break if the heater falls and hits objects or the ground.
- Never use the heater if the glass tube has a crack or chip.

LIGHTING INSTRUCTIONS

Check and ensure that a AA battery is inside the ignition chamber. The anode (+) side of the battery must face out.

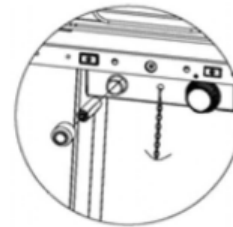

1. Make sure the Control Knob is in the OFF position. Slowly open the LPG cylinder valve.
2. Press and turn the Control Knob to PILOT (⚡) position (counterclockwise). Press the Red igniter button.
3. Check for the pilot flame through the glass tube. If the pilot does not light, press and turn the Control Knob clockwise to the OFF position. Repeat steps 1-2.
4. Once the pilot flame is lit, turn the Control Knob counterclockwise to LO position.
5. For maximum heat, turn the Control Knob counterclockwise to HI position.
6. To turn the heater off, turn the Control Knob clockwise to PILOT (⚡) position. Then depress the Control Knob and turn clockwise to OFF Position. Close the valve on your LPG cylinder when the heater is not in use.

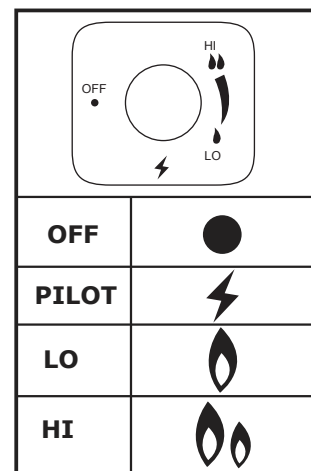

MAINTENANCE / STORAGE

CLEANING & MAINTENANCE:

To enjoy years of outstanding performance from your heater make sure you perform the following maintenance routines on a regular basis:

- Keep exterior surfaces clean:
 - Use warm soapy water for cleaning. Never use flammable, corrosive or abrasive cleaners
 - While washing your unit, be sure to keep the area around the burner and pilot assembly dry at all times. If the gas control is exposed to water in any way, do NOT try and use it. It must be replaced
- At least once a year, the unit should be inspected for spiders, spider webs or other insects - air flow might be obstructed
- Keep controls, burner and circulating air passageways clean. Signs of possible blockage include:
 - Gas odour with extreme yellow tipping of flame
 - Heater does not reach the desired temperature
 - Heater glow is excessively uneven
 - Heater makes popping noises
- Spiders and insects can nest in burners or orifices. This dangerous condition can damage the heater and render it unsafe for use. Clean burner holes by using a heavy duty pipe cleaner. Compressed air may help clear away smaller particles
- Carbon deposits may create a fire hazard. Clean reflector and glass tube with soapy water if any carbon deposits develop. Always be careful when cleaning the glass tube.

STORAGE:

Between Uses:

- Turn the control knob to <<OFF>> position
- Turn the LP cylinder to the <<OFF>> position
- Store the heater upright in an area sheltered away from weather conditions such as rain, sleet, hail and snow
- If desired, cover heater to protect exterior surfaces and to help prevent dust and debris collecting in air passages. Do not apply cover until heater has completely cooled.

DURING PERIODS OF EXTENDED INACTIVITY OR WHEN TRANSPORTING:

- Turn the control knob to <<OFF>> position
- Disconnect LP cylinder and move to a secure, well ventilated location outdoors. Do NOT store in a location that will exceed 120 degrees fahrenheit.
- Store heater upright in an area sheltered away from weather conditions such as rain, sleet, hail and snow
- If desired, cover heater to protect exterior surfaces and to help prevent dust and debris collecting in air passages DO not apply cover until heater has completely cooled.

WARNING FOR YOUR SAFETY

- DO NOT touch or move heater for at least 45 minutes after each use
- Allow all burner elements to cool before touching

NOTE

- In a salt air environment (such as near an ocean) corrosion occurs more quickly than normal
- Frequently check for corroded areas and repair them promptly
- Wait until heater is cool before covering

TROUBLE SHOOTING

PROBLEM	PROBABLE CAUSE	SOLUTION
<i>Pilot will not light</i>	Gas valve may be OFF Fuel tank is empty Orifice blocked Air in supply system Loose connection AA battery is missing or dead	Turn the gas valve ON Refill LPG cylinder Clean or replace orifice Purge air from lines Check all fittings Replace AA battery
<i>Pilot will not stay on</i>	Debris around pilot Loose connection Thermocouple bad Gas leak in line Lack of fuel pressure	Clean dirty area Tighten connections Replace thermocouple Check connections using leak test Fuel tank is near empty. Refill.
<i>Burner will not light</i>	Pressure is low Orifice blocked Control Valve not ON Thermocouple bad Pilot light assembly bent or not in correct location	Fuel tank is near empty Remove,, clean and replace Turn valve ON Replace thermocouple Place pilot light in correct position and retry
<i>Burner flame is low</i>	Supply hose is bent or twisted Blockage in burner injector	Straigten hose and perform leak test on hose Clean or replace burner injector
<i>Burner flame goes off immediately after ignition</i>	Low gas pressure	Let the pilot flame stay light for 10 minutes before setting variable knob to LO
<i>Thick black smoke</i>	Blockage in burner	Turn off the heater and let it cool. Remove blockage and clear burner inside and out
<i>Carbon buid up</i>	Dirt or film on reflector and flame screen	Clean reflector and flame screen

