

**WHISPER LIFT II PRO – 23401
WHISPER LIFT XL PRO - 23601
WIFI ENABLED TV LIFT
OWNER'S MANUAL**

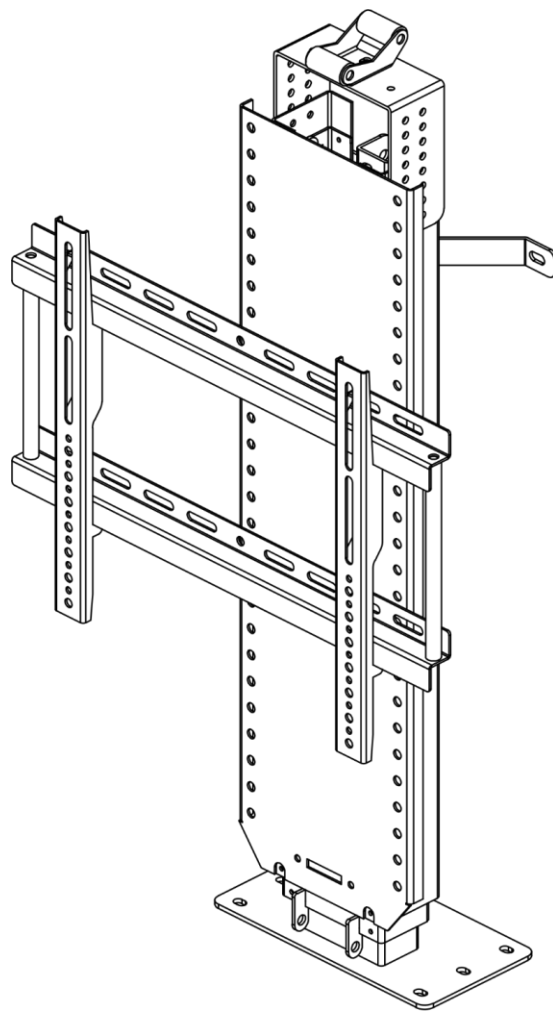



Table of Contents

About Your Touchstone Whisper Lift II PRO/XL PRO Advanced TV Lift	4
Lift Features	4
Technical Specifications	4
Safety	5
IMPORTANT SAFETY and PRE-INSTALLATION INSTRUCTIONS	5
Lift Components & TV Installation Hardware.....	6
Components	6
Hardware.....	6
Dimensional Drawings	7
Assembling and Installing Your Whisper Lift II PRO/XL PRO TV Lift	9
Tools	9
Component Diagram	9
Installing C Bracket	10
<i>C-Bracket Installation Instructions.....</i>	<i>10</i>
<i>Roller Installation Instructions.....</i>	<i>11</i>
<i>Install Rear Brackets.....</i>	<i>12</i>
Fasten Lift To Cabinet.....	13
Hooking Up Lift Components and Operating Lift.....	14
<i>Hooking Up Control Box.....</i>	<i>15</i>
<i>Hooking Up Wired Handset Control.....</i>	<i>16</i>
<i>Hooking Up Power Supply.....</i>	<i>16</i>
<i>Operating the Lift.....</i>	<i>17</i>
Mounting and Installing the TV	21
<i>Attaching TV Mounting Brackets To Flat Panel TV.....</i>	<i>21</i>
<i>Attaching TV Mounting Brackets To Flat Panel TV- cont</i>	<i>22</i>
<i>Assembling The Flat Panel TV Mount.....</i>	<i>23</i>
<i>Mounting Flat Panel TV Mount To The Lift.....</i>	<i>24</i>
<i>Mounting Flat Panel TV Lift Mount – cont.</i>	<i>25</i>
<i>Installing TV on Lift</i>	<i>26</i>
<i>Locking TV to Flat Panel TV Mount</i>	<i>27</i>
Technical Support and Troubleshooting	28
Warranty	29



About Your Touchstone Whisper Lift II PRO/XL PRO Advanced TV Lift

Congratulations on the purchase of your Touchstone Whisper Lift II PRO/XL PRO Advanced TV Lift. Touchstone Home Products takes pride in the quality craftsmanship and smooth functionality of our TV lift mechanism. Please take a few minutes to learn about the features of your TV lift to ensure you get the optimum use and performance from your new purchase.

Lift Features

- Durable steel construction with 24v motor for smooth, quiet and reliable operation
- Lift cycle fully raises or lowers in approximately 30 seconds.
- Universal quick connect installation takes just minutes. Includes hardware kit with bolts for mounting TV brackets to TV.
- 3-way adjustable mounting system to ensure that the Whisper Lift II PRO/XL PRO Advanced TV Lift is compatible with almost all flat panel TVs in the market today.
- Modular design – all components can be easily replaced in just minutes
- Optional component shelf
- 5 year worry-free warranty

Technical Specifications

Specification	23401 – Whisper Lift II PRO	23601 – Whisper Lift XL PRO
Retracted Height (including roller)	32 ½”	40”
Extended Height (including roller)	68 ½”	88 ¼”
Total Travel	36”	48 ¼”
Travel Speed	Approx. 1”/s	Approx. 1”/s
Weight Capacity	100lbs	175lbs
Duty Cycle	5 mins on, 18 mins off	5 mins on, 18 mins off
Working Environment	41°F to 104°F	41°F to 104°F
Input (Power Supply)	100 ~ 240 VAC, 50/60Hz, 1.5A	100 ~ 240 VAC, 50/60Hz, 1.5A
Output (Power Supply)	29.0V, 2.0A	29.0V, 2.0A
Soft Start/Stop	Yes	Yes
Wifi Enabled	Yes	Yes
Voice Controls	Amazon Alexa and Google Assistant	Amazon Alexa and Google Assistant
Retracted Memory Height	Yes	Yes
Extended Memory Height	Yes	Yes
Excess Heat and Load Protection	Yes	Yes
Can Be Used In Drop Down Application (from ceiling)	Yes	Yes

Safety

Mounting your flat screen TV to the Touchstone Whisper Lift II PRO/XL PRO Advanced TV Lift is fast and easy. Operating your lift is very straightforward. However, to avoid the risk of personal injury and to ensure optimum performance of your TV lift mechanism, please pay particular attention to the warnings and safety notices throughout this manual.

IMPORTANT SAFETY and PRE-INSTALLATION INSTRUCTIONS

1. Please adhere to the proper installation procedure as detailed in the installation instructions.
2. Safety precaution measures must be practiced at all times during installation of this product.
3. The entire installation instructions should be fully read and understood before beginning installation.
4. At least two people should be available to lift the TV onto the lift mechanism. Please take care when handling your flat screen TV, as injury and damage can result from dropping or mishandling of the TV.
5. Plasma screen TVs should remain upright at all times. Never place the screen face down on the floor. This could cause damage to the TV.
6. **The stand on your flat screen TV is removable!** Please remove the stand prior to installing the TV on the lift mechanism. Consult your TV's owner's manual for instructions for removing the stand.
7. Carefully measure all dimensions of your LCD, PLASMA, or LED TV before proceeding. Then consult the **Mounting and Installing the TV** section of this manual for maximum TV size.

IMPORTANT!: After installing your TV, you may find there is room in the bottom of the cabinet to install a small cable/satellite TV box. Carefully inspect the space between the bottom of the TV and the bottom of the cabinet to see if your component will fit in the bottom of the cabinet. Consult the **Mounting and Installing the TV** section of this manual for more information.

8. All cords connecting components to the TV should be a minimum of 72" (6 feet) in length when installing components inside of a cabinet or a minimum of 144" (12 feet) in length when installing components outside of cabinet (length of cable will depend on placement of your component).
9. **WARNING!:** TV lift mechanism contains moving parts. Please keep hands, arms, and fingers away from the lift and cabinet lid opening when the lift is in motion. Cables should be wire-tied or secured neatly so lift does not contact them during operation. Also, keep all components away from the lift mechanism.
10. **WARNING!:** DO NOT mount items above the lift that the lift or TV may hit during it's travel. Touchstone Home Products is not responsible for damage to items placed above the TV and TV lift, or items attached to the lift.

Contact Touchstone Customer Service at 1-800-215-1990 with any questions regarding the operation of your Whisper Lift II PRO/XL PRO Advanced TV Lift. We are also available on the web at www.touchstonehomeproducts.com



Lift Components & TV Installation Hardware

Components

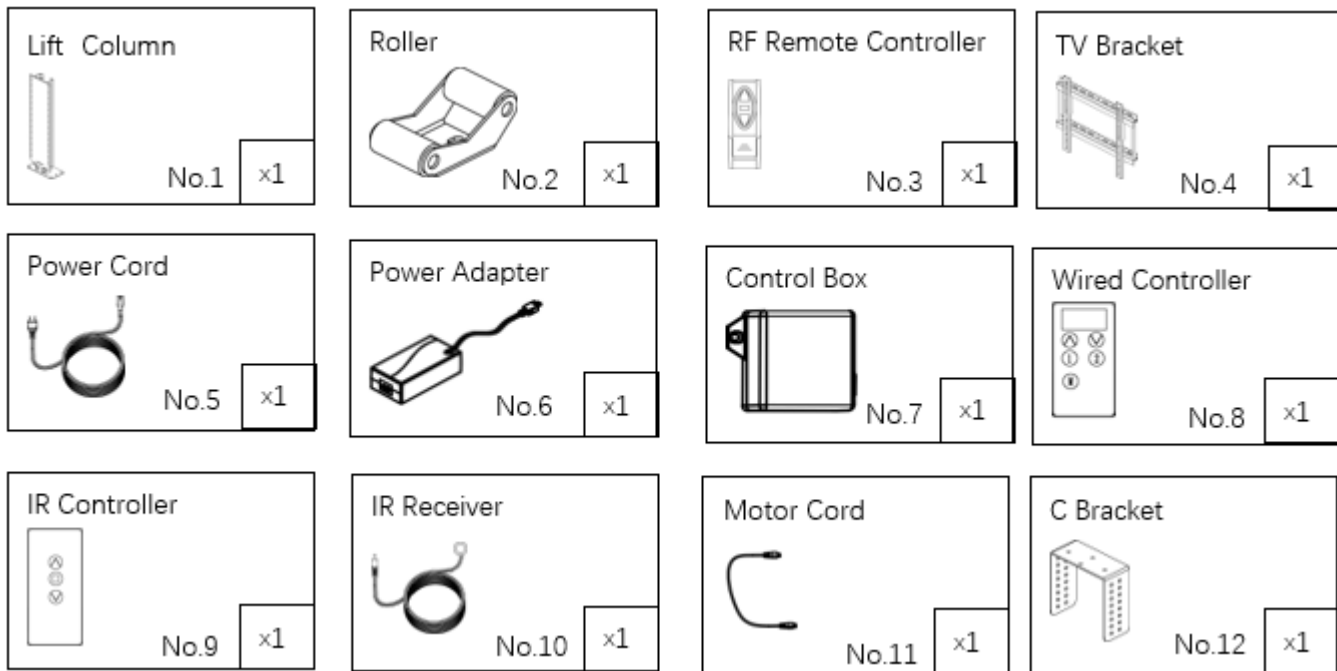

Hardware

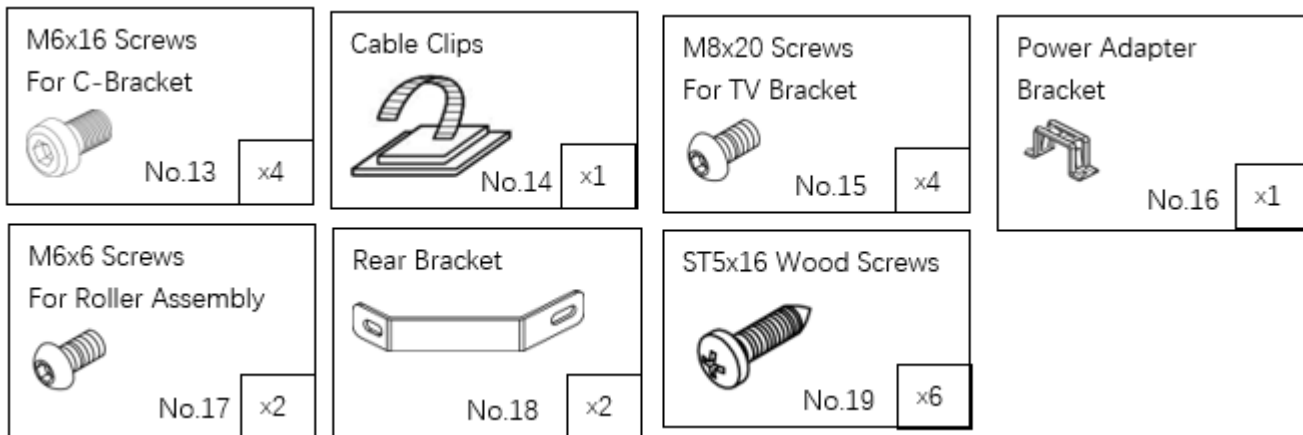

- TV Mounting Screws

-> Please consult your TV manufacturer for the size and length of the mounting screw for your TV. Included is a basic set of mounting screws that accommodates most LCD/Plasma TVs. Depending on your television, the screws included in the kit may not fit your television. If that is the case, these screws can be purchased at most hardware/home improvement stores.

Dimensional Drawings

23401 – Whisper Lift II PRO TV Lift

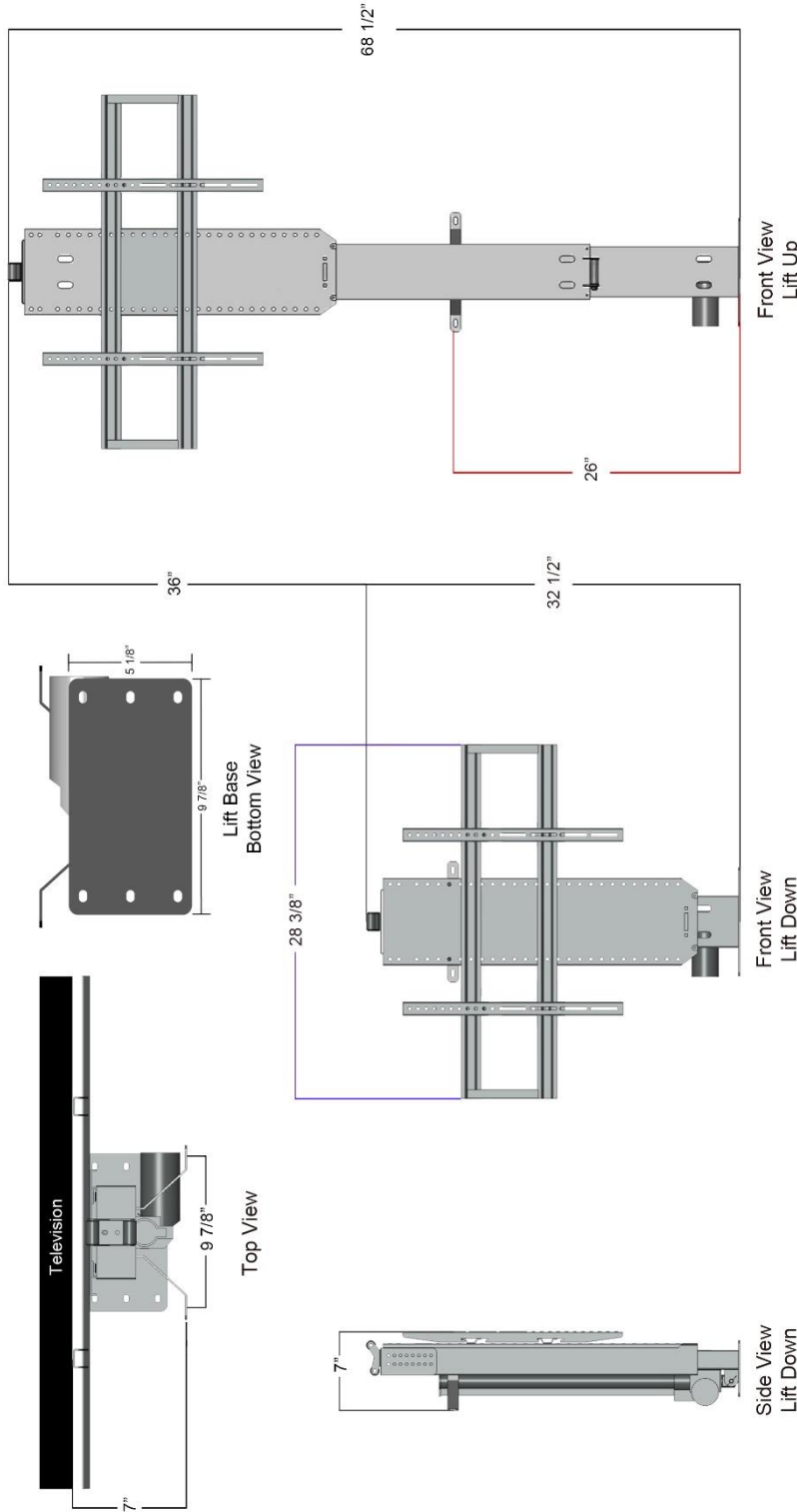

23401 - Whisper Lift II PRO Features:

- Roller system for hinged lids
- Flat top for connected lids (30 3/4" high without roller)
- 100lb weight capacity
- Mounts to the floor and back
- Universal TV mounting brackets included
- Minimum cabinet TV cavity dimensions:
height: 33"
depth: 7" plus TV depth
width: TV width + 1"
- 36" of travel (works with TVs up to 36" tall w/o stand)
- RS232 trigger output
- WiFi Controls through app
- IR control capability
- Set lift height to limit travel of lift
- Can be used in drop down applications

Whisper Lift II PRO Dimensions
PN: 23401



PREMIUM
ELECTRIC FIREPLACES
& TV LIFTS

Exceeding Expectations

Updated: 12/1/2023

23601 – Whisper Lift XL PRO TV Lift

ts touchstone **PREMIUM ELECTRIC FIREPLACES & TV LIFTS** Exceeding Expectations
 Whisper Lift PRO XL Dimensions
 PN: 23601

23601 - Whisper Lift PRO XL Features:

- Roller system for hinged lids
- > Retracted Height: 40 1/4" - 50 1/4"
- > Extended Height: 88 1/2" - 98 1/2"
- Optional Flat Top for connected lids
- > Retracted height: 38 3/4" - 48 3/4"
- > Extended height: 87" - 97"
- 175lb weight capacity
- Mounts to the floor and back
- Universal TV mounting brackets included
- Minimum cabinet TV cavity dimensions:
 Height: 41" (dependent on TV height)
 Depth: 7" plus TV depth
 Width: TV width + 1"
- 48 1/4" of stroke (works with TVs up to 48" tall w/o stand)
- Adjustable top bracket up to 10" of extension
- Can be used in drop down applications

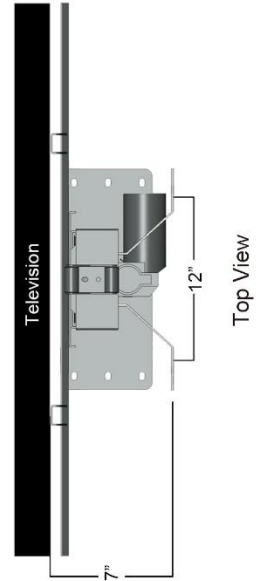
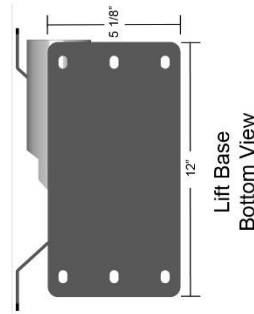
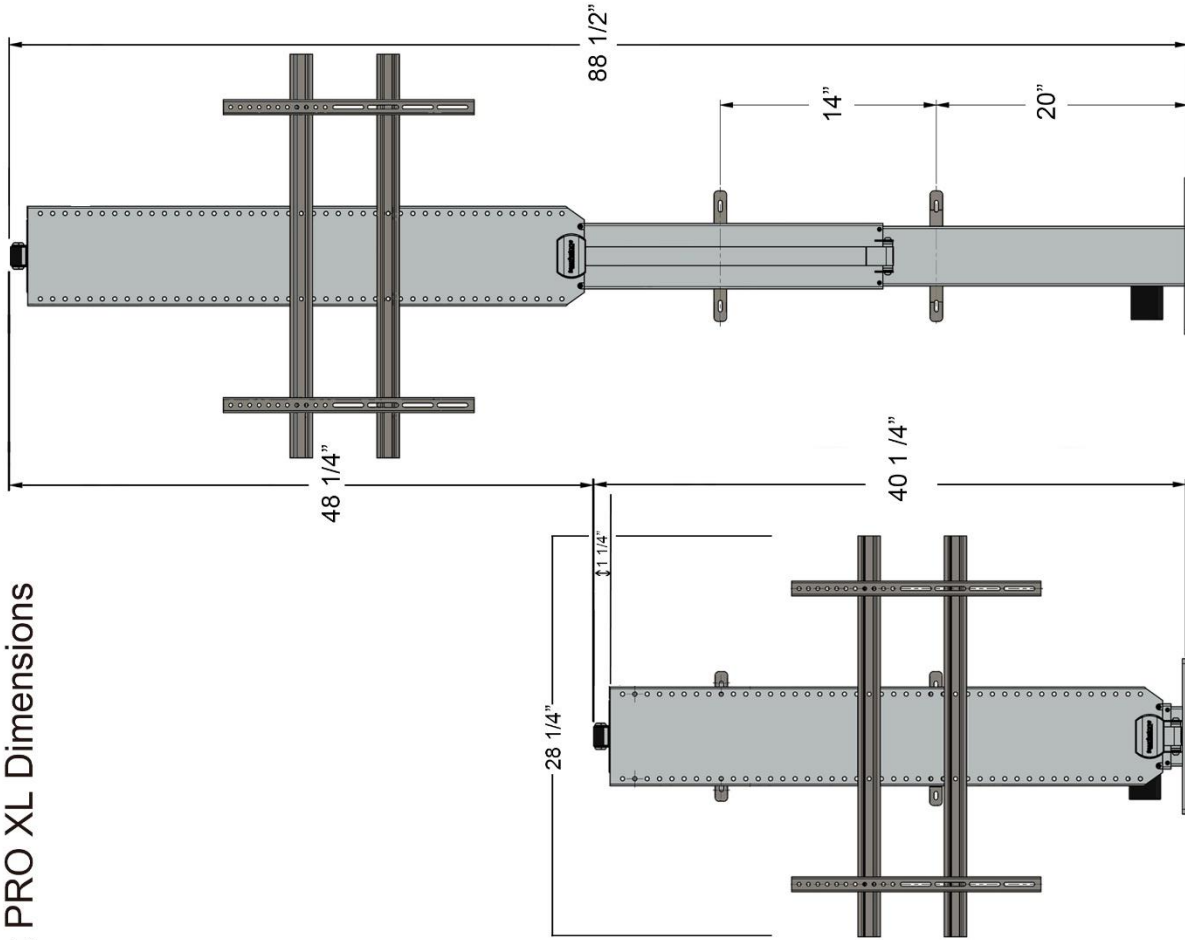

Assembling and Installing Your Whisper Lift II PRO/XL PRO TV Lift Tools

In order to assemble the Whisper Lift II PRO/XL PRO Advanced TV Lift, you will need the following tools:

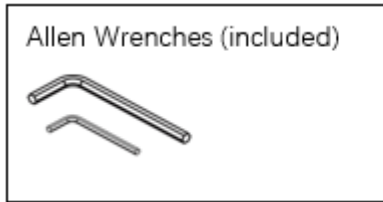

Component Diagram

#	Description	Qty
1	Lift Column	1
2	Roller Assembly	1
3	RF Remote Control	1
4	TV Bracket Assembly	1
5	Power Cord	1
6	Power Adapter	1
7	Control Box	1
8	Wired Controller	1
9	IR Controller	1
10	IR Receiver Sensor	1
11	Motor Cable	1
12	C Bracket	1
13	M6x16 Screws for C Bracket	4
15	M8x20 Screws and Nuts for TV Bracket	4
16	Power Adapter Bracket	1
17	M6x6 Screws for Roller Assembly	2
18	Rear Bracket and Nuts	2

Assembling and Installing Your Whisper Lift II PRO/XL PRO TV Lift - cont

Installing C Bracket

Parts Needed:

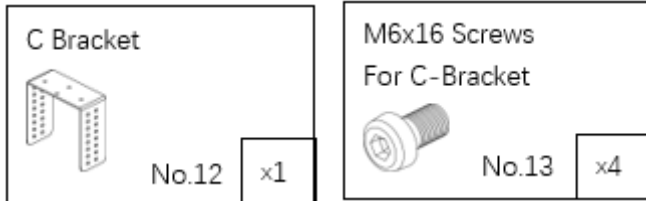

Tools Needed:

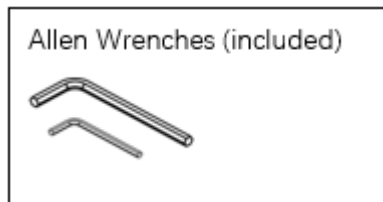

C-Bracket Installation Instructions

The adjustable C-Bracket is mounted to the top of the lift for adjusting the height of the lift as needed in your cabinet. Follow the instructions below for installing the C-Bracket on the lift:

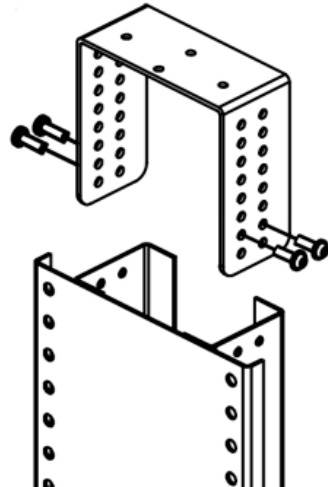
<ol style="list-style-type: none">Using the 4 M6x16 bolts (13), attach the C-Bracket (12) to the top of the lift. The holes in the C-Bracket are spaced 1/2" apart and allow for adjusting the height of the lift as needed to fit your cabinet. For the lowest height, place the bolts in the top set of holes on the C-Bracket. For the highest height, place the bolts in the lowest set of holes on the C-Bracket	
---	---

Assembling and Installing Your Whisper Lift II PRO/XL PRO TV Lift - cont

Roller Installation Instructions

The Whisper Lift II PRO/XL PRO ships with roller that mounts to the top of the lift for use with hinged lids. If installing the lift in a cabinet with a hinged lid, install the roller on the top of the lift.

Parts Required:

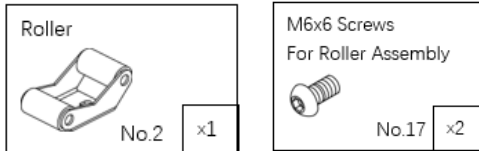

Tools Required:

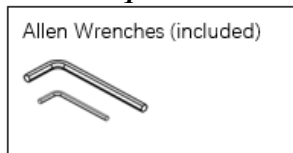

Instructions:

1. Line the mounting holes in the roller (2) up with the 2 holes in the bracket on the top of the lift. The higher roller will face toward the front of the lift, with the lower roller facing toward the back of the lift. Attach the roller to the C-Bracket using 2 M6x6 screws (17).

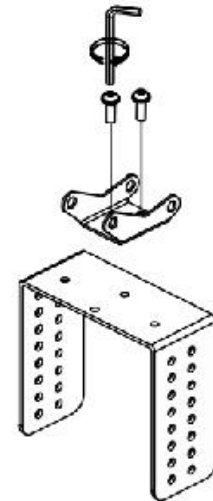

2. After roller bracket is attached to the C-Bracket, install the 2 rollers.

Note: *The higher roller should be pointed toward the front of the lift.*

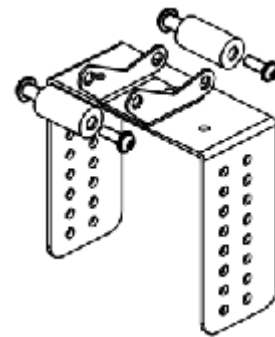

Assembling and Installing Your Whisper Lift II PRO/XL PRO TV Lift – cont

Install Rear Brackets

Prior to installing your TV lift, install the 2 rear support brackets on the back of the lift:

Parts Required:

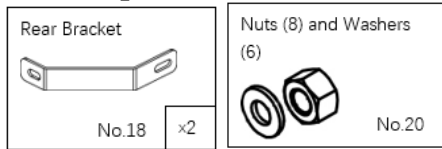

Tools Required:



****Only 2 nuts are needed for installing the rear brackets**

Instructions:

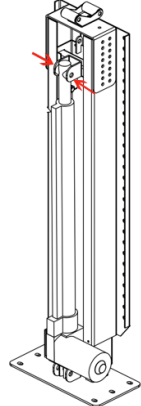
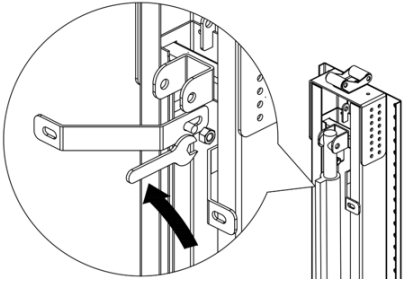
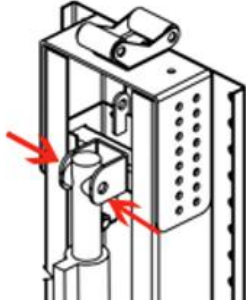
<p>1. With the lift in the lowest position, use the 2 allen wrenches to remove the 2 hex bolts securing the top part of the actuator to the lift as shown below.</p>	
<p>2. Move the top of the actuator head back and install the 2 rear support brackets on the lift using 1 nut to secure each brackets as shown. Tighten each bracket with the supplied wrench or an adjustable wrench.</p>	
<p>3. Once the rear brackets are installed, reattach the top of the actuator to the lift.</p>	

Fasten Lift To Cabinet

The Whisper Lift II PRO/XL PRO TV Lift has 8 mounting points (2 on the back of the lift and 6 on the floor). Use the 2 rear mounting points and the 6 floor mounting points to mount the lift in your cabinet.

Tools Required:

- Screwdriver or cordless-drill

Note: The customer is responsible for providing their own screws to fasten the lift to the cabinet. Please use a screw at least 1 ½" long, or larger if possible, depending on the thickness of the wall/floor of your cabinet.

Instructions:

1. Line up the lift with the mid-line of the cabinet.

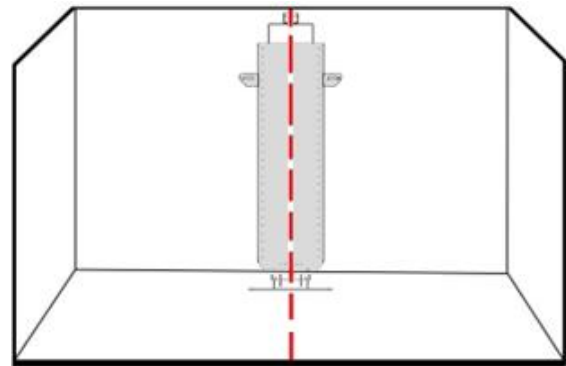
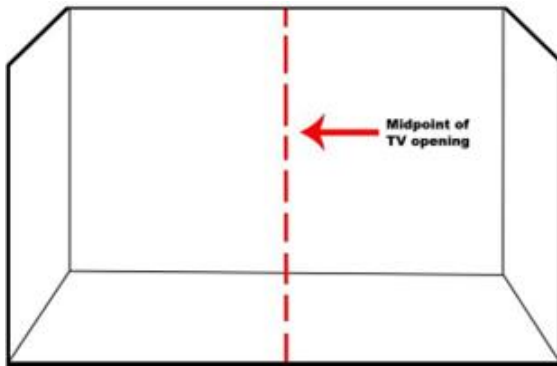

2. Once the lift is placed in the cabinet and aligned with the center of the cabinet, fasten the lift to the back wall of the cabinet (2 screws) and the floor of the cabinet (6 screws – 3 on each side of the lift).

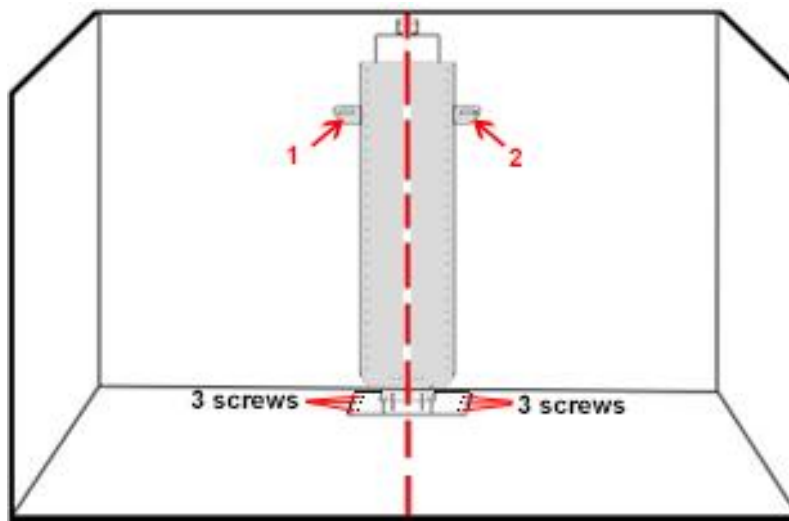

Hooking Up Lift Components and Operating Lift

Once the TV Lift is installed in the cabinet, the individual lift components can be attached to the lift. The following components will be needed:

- Lift Control Box
- Power Supply
- Wired Hand Set Control

Parts Required:



Control Box



Motor Cable

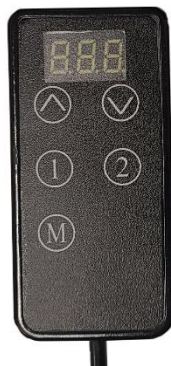

Wired Handset Control



Power Supply



Power Supply Power Cable

Hooking Up Control Box

Instructions:

1. Attach one end of the motor cable (11) to the actuator extension cable that is connected to the lift.

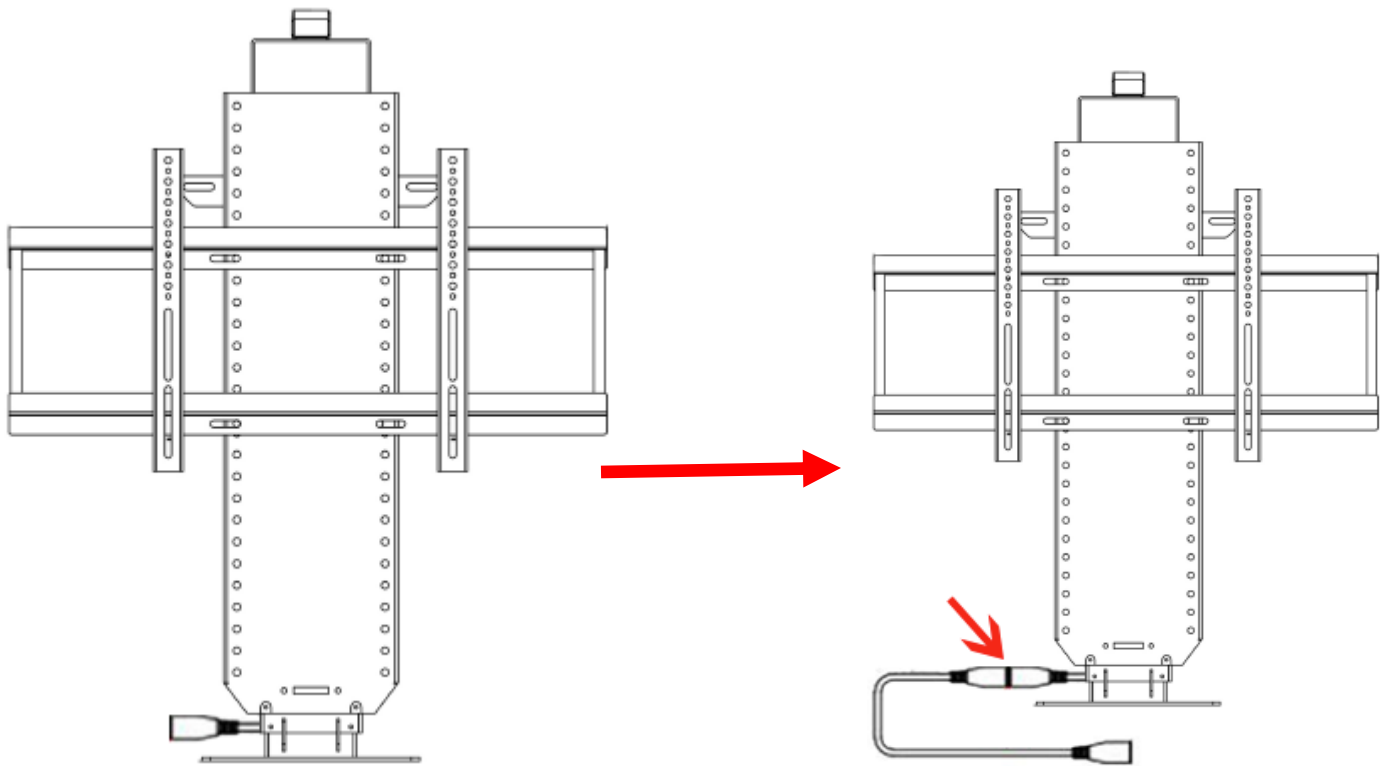

2. Attach the other end of the motor cable (11) to the control box (7) in the port shown below.

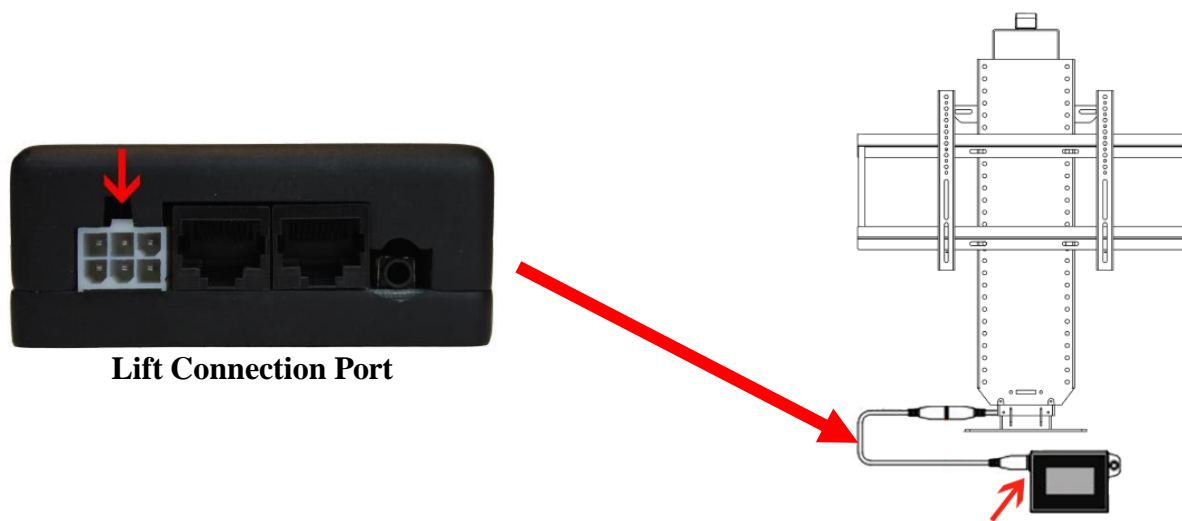

Hooking Up Wired Handset Control

Instructions:

1. Plug the wired handset control into appropriate port on the control box shown below.

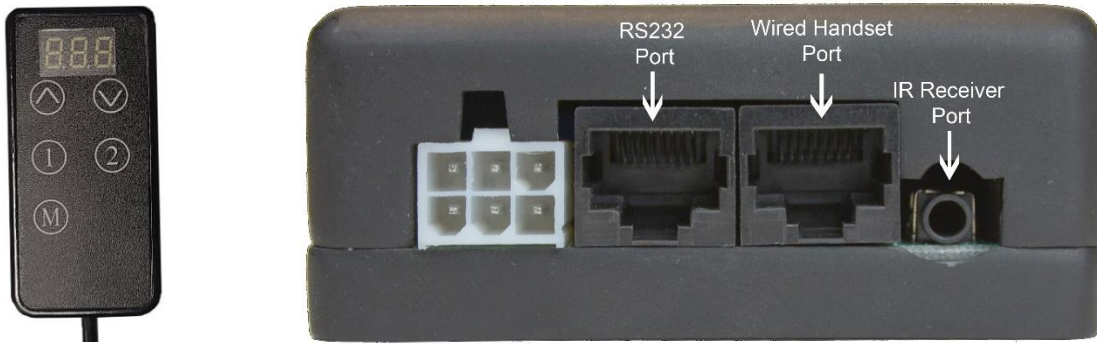

Hooking Up Power Supply

Instructions:

1. Attach the power supply transit cable (A) to the power supply and plug the power supply cable (B) into the control box.

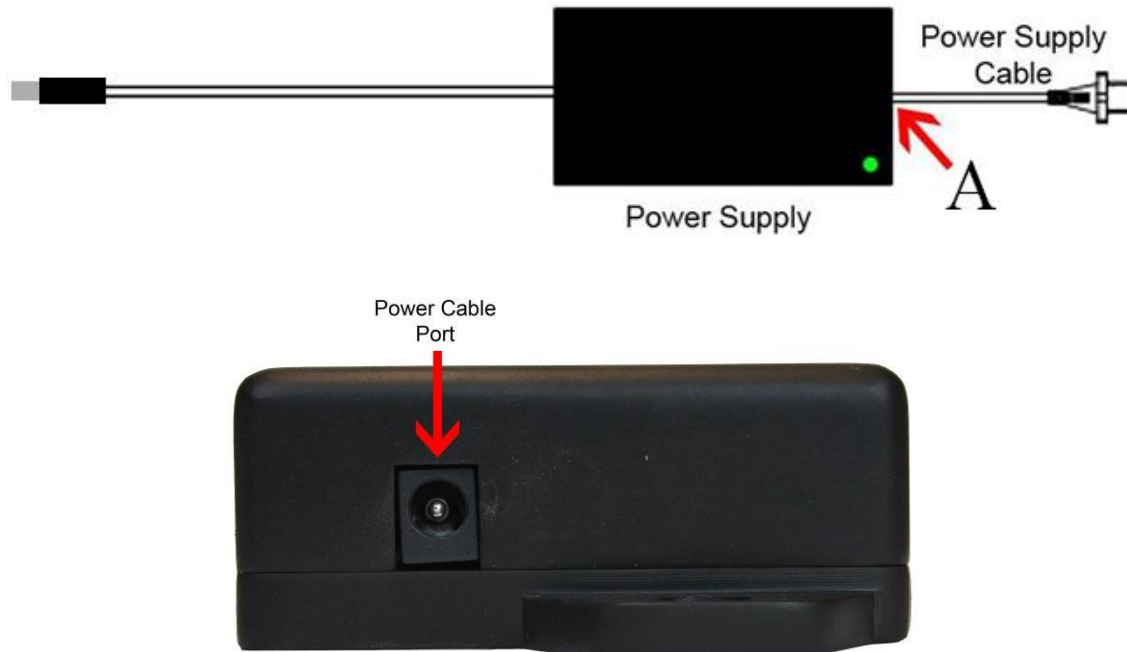







2. When complete, plug the lift power cable into a wall outlet to power the lift.

Operating the Lift

The Whisper Lift II PRO/XL PRO TV Lift can be controlled through the provided wired handset controller or the wireless remote control.

Wired Handset Control

 <p>Wired Handset Control</p>		<p>Lift Height: Shows the height of the lift in inches.</p>
		<p>UP Button: PRESS and HOLD this button to raise the lift. Releasing this button will stop the lift.</p> <p>**Note: <i>If a memory height is set, holding the UP button will ignore the memory height and the lift will continue to run past the set memory height.</i></p>
		<p>DOWN: PRESS and HOLD this button to lower the lift. Releasing this button will stop the lift.</p>
		<p>MEMORY: The lift can be set to 2 memory positions, an extended memory and retracted memory position. To set the memory position, raise the lift to the desired position. Follow the instructions under 1 and 2 below to set the Extended and Retracted Memory position.</p> <p>When the memory position is set, the UP button on the RF Wireless Remote and IR Wireless Remote will go to the memory height that was set.</p>
		<p>EXTENDED MEMORY POSITION: To set a memory position for the extended height of the lift, do the following:</p> <ol style="list-style-type: none"> Using the UP button on the wired controller, move the lift to the desired height PRESS and RELEASE the M button once PRESS and RELEASE the 1 button. The extended memory height will now be set.
		<p>RETRACTED MEMORY POSITION: To set a memory position for the lower height of the lift, do the following:</p> <ol style="list-style-type: none"> Using the DOWN button on the wired controller, move the lift to the desired height PRESS and RELEASE the M button once PRESS and RELEASE the 2 button. The retracted memory height will now be set.



NOTE: *For applications where fixtures are mounted above the lift and in the path of the lift travel, please use the WIRED HANDSET ONLY to avoid damages to the lift and other items!*

Operating the Lift – cont.

Wireless RF Control

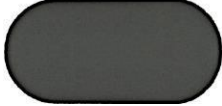

Wireless RF Remote

Wireless RF Remote Button	Function
	<p>UP Button: PRESS the button once to raise the lift. The lift will raise all the way up unless the stop button is pressed, if no memory position is set.</p> <p><i>Note: When a memory position is set, the lift will travel to the memory position when the UP button is pressed.</i></p>
	<p>DOWN: PRESS the button once to lower the lift. The lift will lower all the way down unless the stop button is pressed or a lowest memory position is set.</p>
	<p>STOP: Press the button once to stop the lift.</p>

NOTE: For applications where fixtures are mounted above the lift and in the path of the lift travel, please use the WIRED HANDSET ONLY to avoid damages to the lift and other items, if a memory height is not set!

Pairing RF Remote Control to Control Box

The wireless RF remote will be paired to the Whisper Lift II PRO/XL PRO TV Lift out of the box. Should the wireless RF remote stop functioning, please follow the instructions below for pairing the RF remote control to the lift:

1. Unplug the power cable from the lift control box.
2. Wait 5 seconds and plug the lift power cable back into the control box.
3. Within 5 seconds of plugging the power cable into the control box, press and release the UP button one time on the wireless RF remote after plugging the power cable to control box.
4. The wireless RF remote is now paired to the lift and ready for use.

Operating the Lift – cont.

Advanced Automation Controls

The Touchstone Whisper Lift II PRO/XL PRO Lift control box comes equipped with additional input/output features that allow you to connect external devices, such as third-party automation systems that can be controlled by a universal remote control.

The control box can be controlled via an infrared remote control or connected to your automated system using the RS232 connection.

Wireless IR Control

The Whisper Lift II PRO/XL PRO can be controlled via infrared (IR) through the provided IR sensor and IR remote control.



Setting Up the IR Sensor

1. Plug the IR sensor cable into the IR port on the control box. The IR port location is shown on p. 16.
2. Place the IR sensor in a spot where the remote control will have direct line of sight to the sensor.

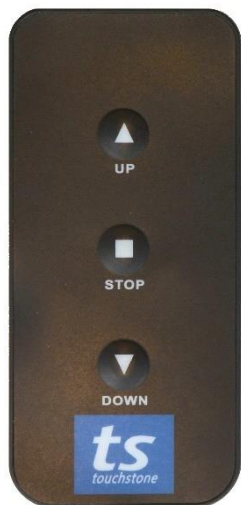
Wireless IR Controls

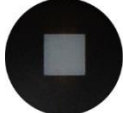

Wireless IR Remote

Wireless IR Remote Button	Function
	UP Button: PRESS the button once to raise the lift. The lift will raise all the way up unless the stop button is pressed, if no memory position is set. Note: When a memory position is set, the lift will travel to the memory position when the UP button is pressed.
	DOWN: PRESS the button once to lower the lift. The lift will lower all the way down unless the stop button is pressed.
	STOP: PRESS the button once to stop the lift.

NOTE: For applications where fixtures are mounted above the lift and in the path of the lift travel, please use the **WIRED HANDSET ONLY** to avoid damages to the lift and other items!

Operating the Lift – cont.

RS232 Controls

The Touchstone Whisper Lift II PRO/XL PRO TV Lift can also be controlled by third-party automation systems via a RS232 serial connection. The input connector on the control box uses a standard RJ-45 connection. The pinout of the connector is illustrated below. The instruction set is also listed in the tables below.

RS-232 is a standard communication protocol that is widely used to connect various devices to external controllers. Automated theater systems, such as Crestron and Control4, for example, can be connected to the control box via the RS-232 connection, and a single device can operate the TV, raise the lift, operate AV systems, etc.

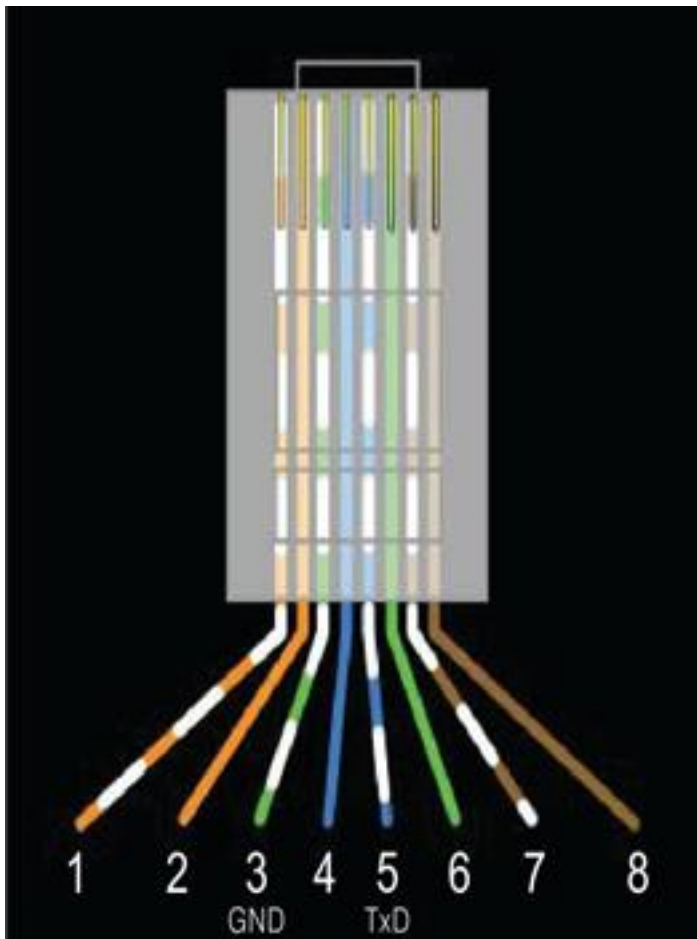

PINOUT Connections	
3	GND
5	TxD

RS232 Configuration	
BAUD RATE	1200
DATA BITS	8
STOP BIT	1
PARITY	NONE
FLOW CONTROL	NONE

RS232 Connection Instruction Set		
ACTION	ASCII	HEX
UP	UP	5550
DOWN	DN	444E

Note: Once Lift memory height has been set, the UP ACTION will only raise the lift to the set height.

Mounting and Installing the TV

IMPORTANT: Prior to installing the TV onto the lift, please ensure the following:

- If you have not done so already, remove the stand from your flat screen TV.
- Maximum lifting capacity:
 - 23401 – Whisper Lift II PRO TV Lift: 100 lbs
 - 23601 – Whisper Lift PRO XL TV Lift: 175 lbs
- TV has VESA compliant mounting pattern.

Attaching TV Mounting Brackets To Flat Panel TV

Tools Required:

- Phillips head screwdriver

Parts Required:

- TV mounting brackets
- TV mounting screws

***Note: Touchstone Home Products includes a screw pack containing some of the most popular sizes of mounting screws, used by most TV manufacturers. Due to the amount of TVs in the marketplace and no standard for mounting screw size, Touchstone Home Products cannot guarantee that the screws required for your TV are included in the screw pack. Please consult your TV manufacturer for the size of the mounting holes in the back of your TV and use the appropriate size screws. Touchstone Home Products assumes no liability for damage to a TV.

Instructions:

1. Remove stand from TV. Consult TV manual for instructions on removing the stand from the TV.
2. Locate the TV mounting brackets. They are pictured below.



**TV Mounting
Brackets**

Attaching TV Mounting Brackets To Flat Panel TV- cont

3. Align TV mounting brackets so that brackets are centered on the back of the TV. Place the TV mounting bracket so that the round holes are toward the top of the TV, while the elongated holes are toward the bottom of the TV.

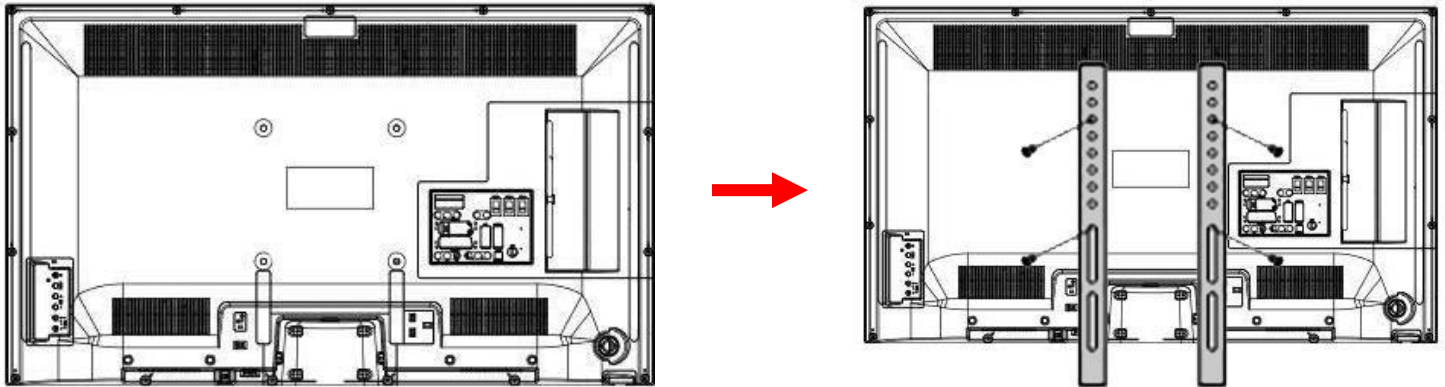

4. Attach TV mounting brackets to back of TV. Consult your TV owner's manual for the proper size mounting screw.

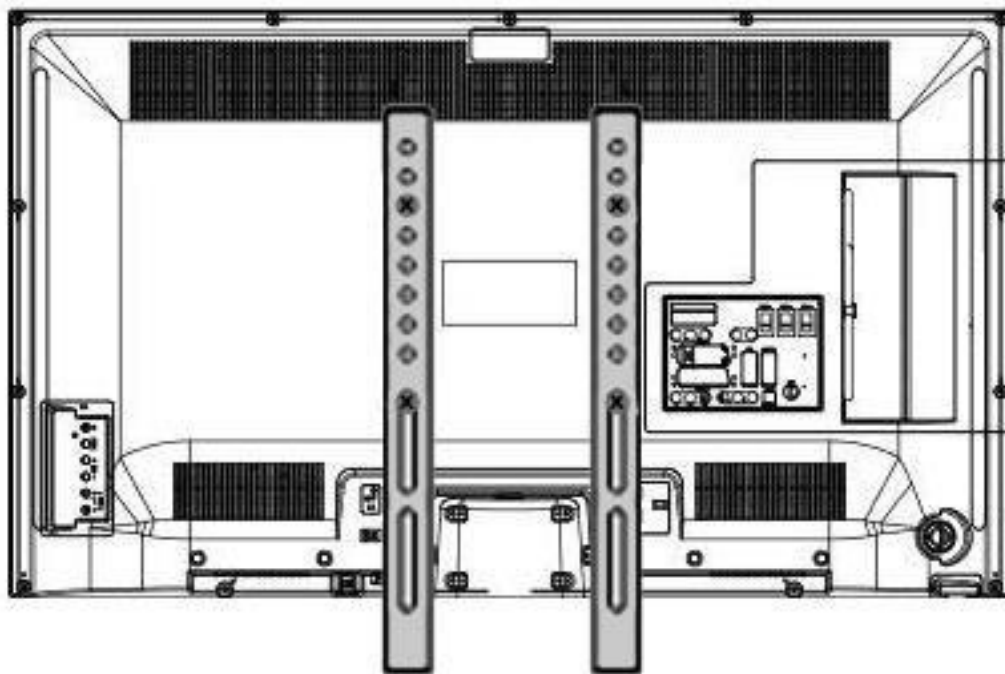

Assembling The Flat Panel TV Mount

Tools Required:

- Phillips head screwdriver

Parts Required:

- 2 horizontal flat panel TV mounting brackets
- 2 vertical rods
- 4 mounting screws and washers

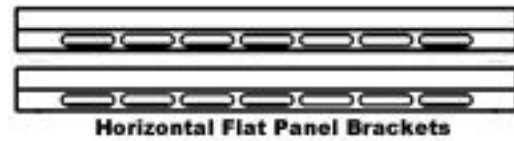

Instructions:

1. Attach the 2 vertical flat panel bracket rods to the top horizontal flat panel bracket. The elongated holes in the horizontal bracket should be facing down.

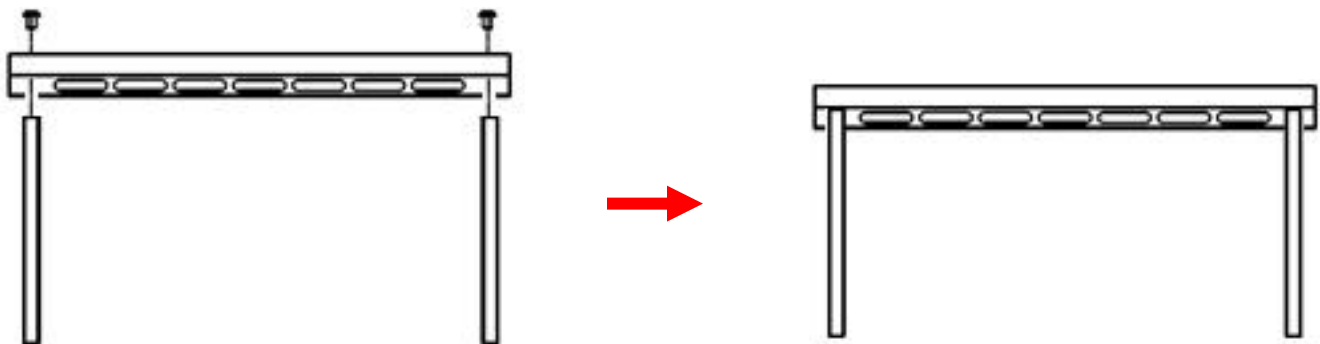

2. Once the vertical flat panel bracket rods are attached to the top horizontal flat panel bracket, attach the lower horizontal flat panel bracket to the vertical flat panel bracket rods. The elongated holes in the horizontal bracket will face down.

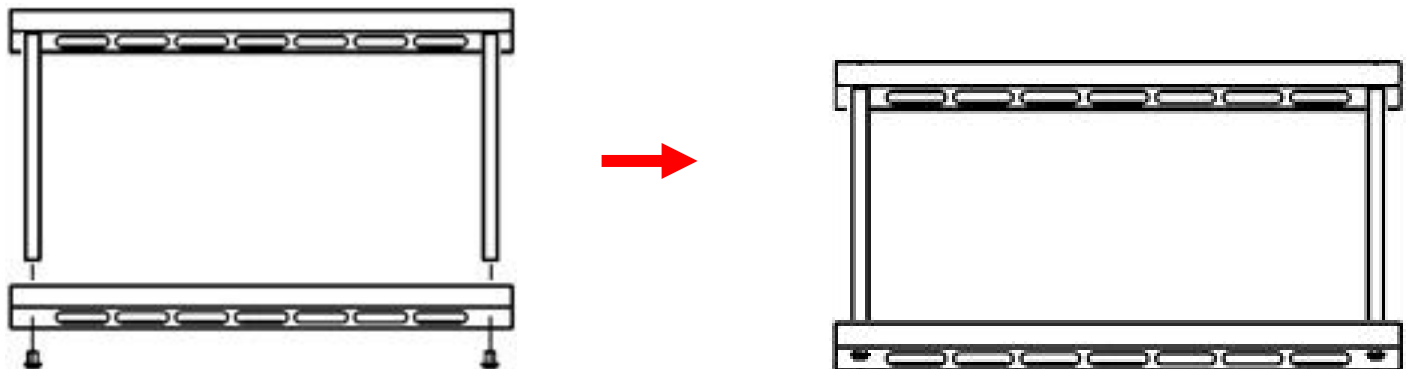

Mounting Flat Panel TV Mount To The Lift

Tools Required:

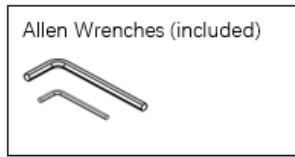

- Adjustable wrench

Parts Required:

- Horizontal flat panel TV mount
- TV Lift
- 4 M8x20 bolts (15)
- 8 washers and 4 nuts (20)

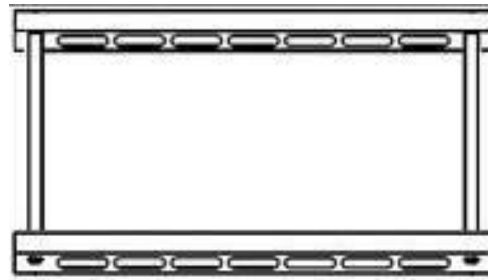

TV Lift Bracket Assembly

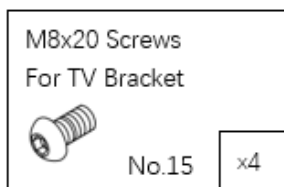
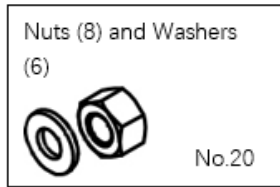

Instructions:

1. Determine the placement for the horizontal flat panel TV bracket on the lift. The bottom of the TV should be just above the base of the TV lift.
2. Place 1 washer on each M8 bolt as shown below:

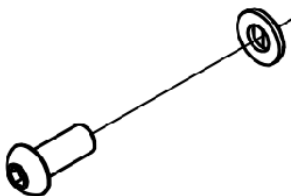

Mounting Flat Panel TV Lift Mount – cont.

3. Using the 4 M8x20 bolts and nuts, mount the horizontal flat panel TV bracket to the lift (**Note:** The position of the horizontal bracket will depend on the height of your TV. The top of the TV should not be higher than the top of the lift when mounted on the lift). Use 1 washer between the nut and back of the lift mounting plate. Tighten bolts so bracket is secure to lift.

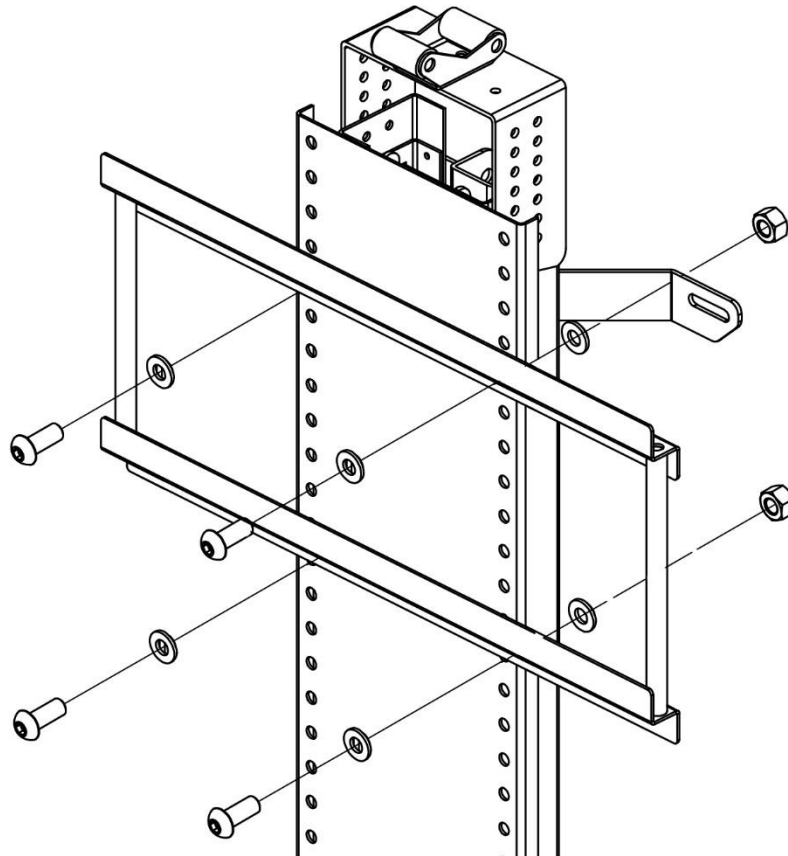

4. Once the TV mounting bracket is installed on the lift, the TV is ready to be installed.

Installing TV on Lift

1. Using the wired handset control, press the UP button to move the lift to the highest position.



2. Hang TV on top crossbracket so that the top set of hooks on the TV bracket overlap the top bar of the flat panel TV mount.

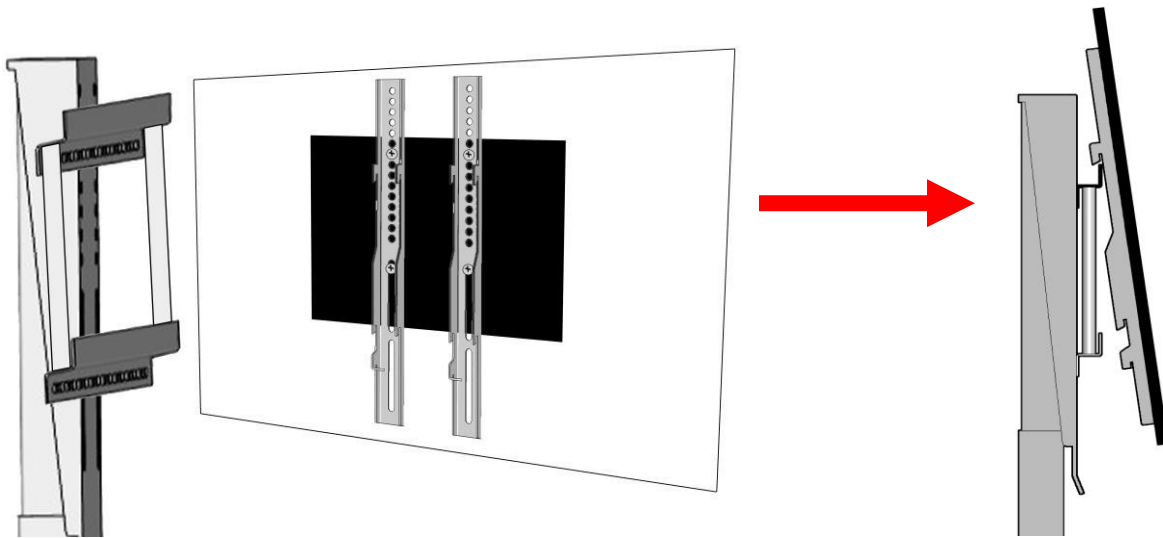

3. With the top set of hooks on the TV bracket overlapping the top bar of the flat panel TV mount, push the bottom of the TV back toward the lift (figure a). Then slightly raise the TV so that the bottom set of hooks on the TV bracket clears the bottom crossbracket of the flat panel TV mount. Lock the TV brackets back down into place (figure b). The TV brackets will now hook over both crossbrackets on the flat panel TV mount (figure c).

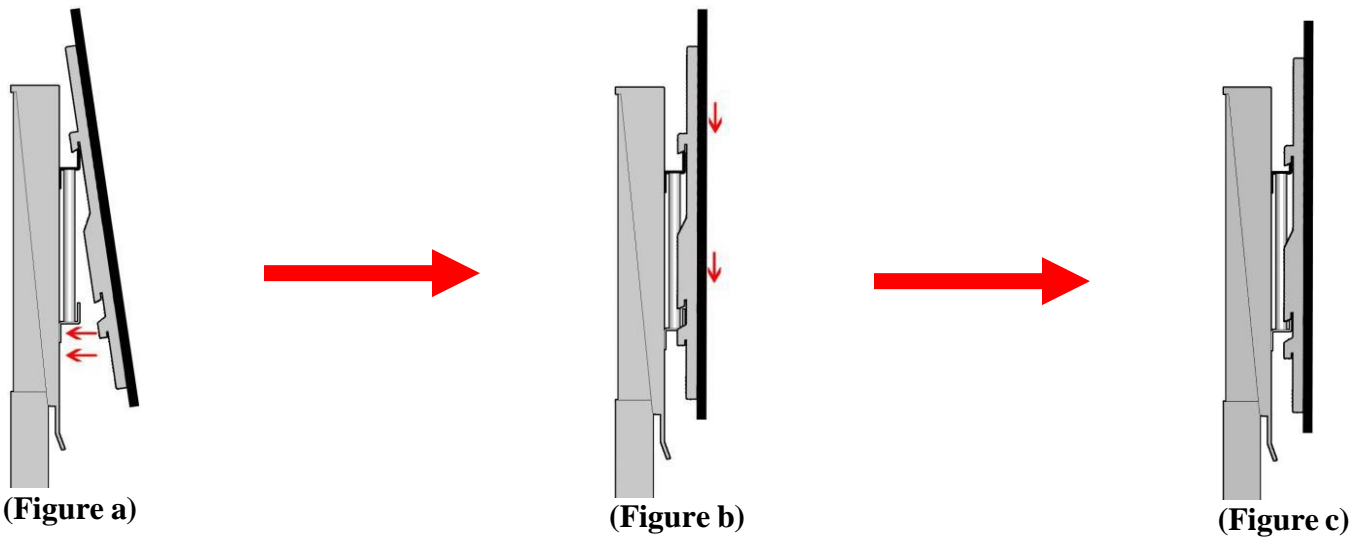

Locking TV to Flat Panel TV Mount

Once the TV is mounted to the lift, the TV can be locked to the flat panel TV mount so that the TV does not slide from side to side. To lock the TV into place, tighten the 2 long screws on the bottom of each TV bracket. The screws will tighten so that they lock against the bottom crossbracket of the flat panel TV mount.

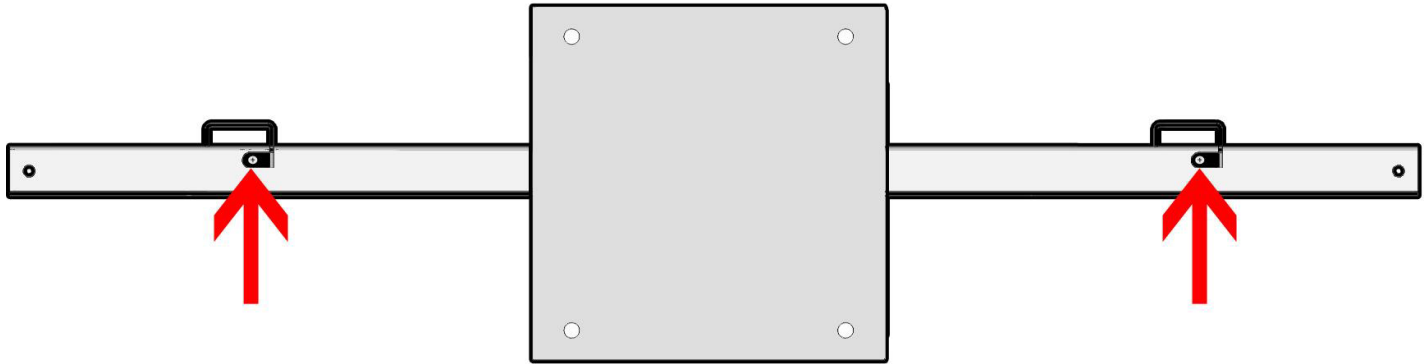

(view of locking screws from underneath TV)

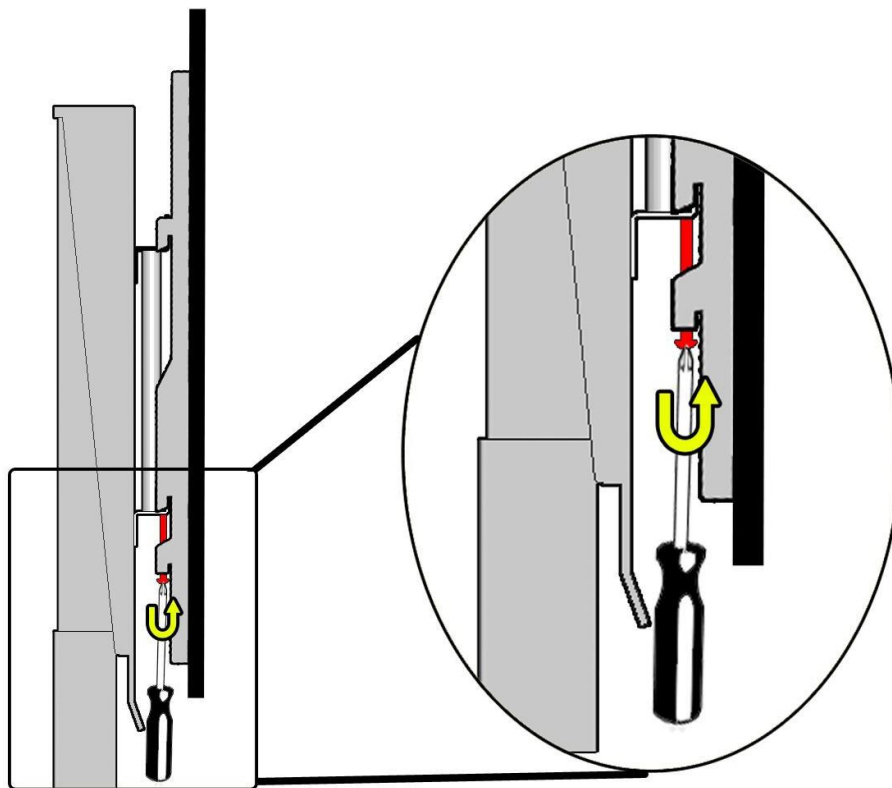

Turn both screws to lock the screw against the bottom bracket of the flat panel TV mount.

Technical Support and Troubleshooting

Should you have any problems with your Touchstone Home Products Whisper Lift II PRO/XL PRO TV Lift, our technical support staff is here to help. Our technical support reps are available by phone at 1-800-215-1990 Monday to Friday, from 8:00am to 5:00pm EST. We also can be reached via email at support@touchstonehomeproducts.com

If the lift should error, an error code will be displayed on the wired handset control. The error codes are listed below:

Error Code	Issue	Troubleshooting
E01	<ol style="list-style-type: none"> One of the control box connection cables is loose, not connected or broken. Lift motor signal loss. 	<p>Step 1: Check the cables and make sure they are properly secured to the control box and lift. Once connected, wait 3 seconds to see if the error disappears.</p> <p>Step 2: 3 seconds after restoring power, the error code should automatically disappear. If not, there is an issue with the motor and the lift will need to be replaced and reset.</p>
E07	<ol style="list-style-type: none"> Load weight is over 177 lbs. Electric current exceeds maximum value set. The lift will not move until the electric current decreases below the maximum set value. 	<ol style="list-style-type: none"> Remove items from lift so that load weight is not over 177 lbs. Once the electric current decreases below the maximum set value, the code will automatically disappear.
E08	The power voltage is lower than what is required to operate the lift.	Once the power voltage resets to the normal value, the code will automatically disappear.
E09	The power voltage is higher than what is required to operate the lift.	Once the power voltage resets to the normal value, the code will automatically disappear.
HOT	Control Box Temperature Protection (If the control box control box's temperature is above 167°F (75°C) or system has been run continuously for 2 minutes)	<ol style="list-style-type: none"> Wait 18 minutes and then the code will disappear and the lift will operate normally. Unplug the power cable, wait 30 seconds, and plug power cable back into outlet. The error code will automatically disappear.
E10	The handset was plugged in after the control box already had power.	Wait 1 second and the code will automatically disappear.

Resetting the Lift

To reset the lift, PRESS and HOLD the DOWN button for 5 seconds. After 5 seconds, the display will read “rES”

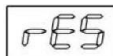

. While continuing to hold the DOWN button, the lift will then lower to the lowest height and then slightly raise. Once reset is completed, release the down button.

Warranty

Touchstone Home Products warrants the Whisper Lift II PRO TV Lift and Whisper Lift XL PRO TV Lift to be free from defects in material and workmanship for five (5) years from date of purchase. The warranty includes all parts, motorized components, electronics, and metal. If the Whisper Lift II PRO TV Lift or Whisper Lift XL PRO TV Lift proves to be defective in material or workmanship during the warranty period, Touchstone Home Products will replace the defective part free of charge. The replacement part will then be covered by the balance of the time remaining on the customer's original warranty.

Touchstone Home Products' warranty does NOT cover: any product on which the serial number has been defaced, modified or removed; damage, deterioration or malfunction resulting from accident, misuse, neglect, power surges, fire, water, lightning damage, or other acts of nature, unauthorized product modification, failure to follow instructions supplied with the product, repair or attempted repair by anyone not authorized by Touchstone Home Products, causes external to the product such as electric power fluctuations or failure, use of supplies or parts not meeting Touchstone Home Products specifications, or any other cause which does not relate to a product defect.







STOP CALL US FIRST! STOP
DO NOT RETURN TO STORE.

For immediate help with assembly, product information,
or if your product arrives damaged, call our toll-free number at

800-215-1990

or email:

customerservice@thpus.com

Our staff is ready to provide assistance.